

Billi Alpine 060 with Round Slimline Dispenser

The Alpine Chilled (still) drinking water system, is a mid-sized commercial capacity system, that maintains Billi's core design principles of space saving and vent-free installation. Dispensing chilled water on demand, with a continuous supply of cool filtered water once tank capacity is depleted, the Alpine range is convenient and highly functional in offering uninterrupted hydration.

The Slimline dispenser offers a sophisticated and clean aesthetic, with a simple self-return pin lever operation for safety & sustainability.



CHILLED



Up to 12

Features



AUSTRALIAN
DESIGNED
& MADE



WATER
COOLED
TECHNOLOGY



SPACE SAVING
DESIGN



VENT-FREE
INSTALLATION



ECO-INTELLIGENCE
ENERGY MODES



UNLIMITED
FILTERED
WATER

Round Slimline
Dispenser



Alpine 060
Under-Bench Unit



Finishes

Standard Finishes



CH -
Chrome



BR -
Brushed



MB -
Matte Black



MW -
Matte White

Special Order Finishes



UB -
Urban Brass



GM -
Gun Metal Grey

Add the relevant Finish Code to the Product code to complete your specification eg 932060RCH-LF

Accessories

992810 - Slimline Font



990724 - Tubing Extension Kit for Slimline 2mtrs

Product Specifications

Water Type	C
Dispenser	R - Round Slimline Dispenser
Mixer Tapware	N/A
Product Code	932060R
Warranty	3 years manufacturers warranty
Under-Bench Dimensions	180mm(W) x 340mm (H) x 460mm (D)
Boiling Output	N/A
Chilled Output	Up to 60 cups per hour
Sparkling Output	N/A
50°C Hot Water Output	N/A
Min / Max Dispenser Temp	6°C / 12°C
Power Plug	10 amp
Power Rating	300W, 220-240V, 50-60Hz
Water Pressure	Min. 250kPa
Ecolabel	N/A
EPD	N/A
Greenstar Contribution	N/A
Watermark License	WM-021882
Lead Free	✓
Section J7.7 (NCC)	✓
WELS	N/A
WELL	Cornerstone Membership
Management Systems	Every Billi drinking water appliance is manufactured under the strictest standards and is certified in accordance with: ISO9001 for QMS (FS 790754), ISO14001 for EMS (EMS 801468) and ISO45001 for OSHS (OHS 801469).
Food Handling	HACCP License No. PE-138-BIL-R1-02
Filtration	994051 - 5.0 Micron supplied standard

Scan the QR code access
our Revit families on
bimstore



Technical Drawings

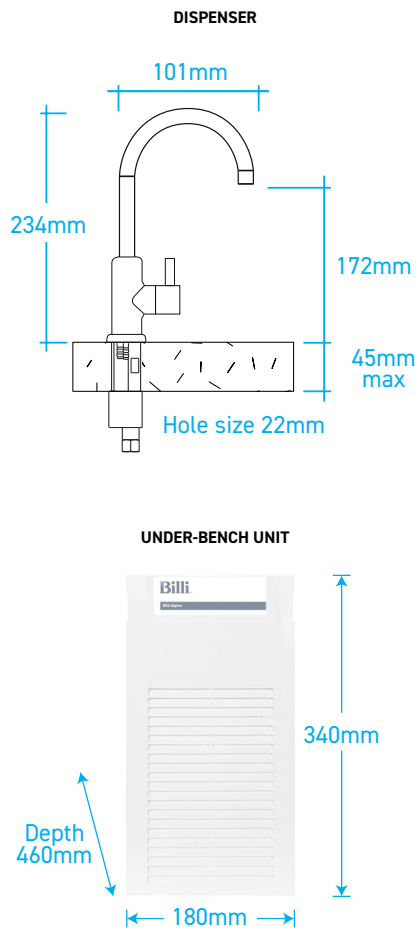

* Drawings are for guidance during Specification, refer to Installation requirements for final install. All efforts are made to ensure Compliance & Certifications claims are current, however this is subject to change without notice. Billi assumes no liability or responsibility for out of date information.

Installation Requirements

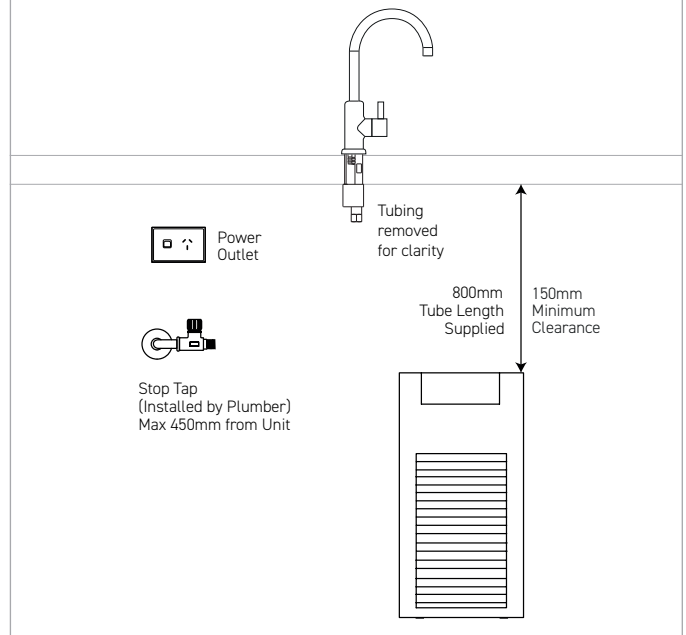

Installation Notes

- Electrical** A standard 10 amp power outlet is required, located no further than 1000mm from the underbench unit. The system is supplied with a 1 metre flex cord and plug.
- Water** A single 1/2" BSP (15mm) stop-tap with a male thread should be installed in an easily accessible position. Water supply must be microbiologically safe to drink, with a minimum dynamic water pressure of 250kPa and a maximum of 1000kPa.
- Pressure Valve** Integrated 500kPa pressure limiting and dual check valve is pre-installed to the unit inlet.
- Stone Benches** Billi has a no-cut policy regarding all stone benches in compliance with regulations. The safety of our team and customers remains Billi's top priority.
- Ventilation** No joinery ventilation or accessories are required for this Billi product (water cooled technology).

Filtration - Most Recommended Replacement Filters

Billi range of premium filters utilize BWT's unique FibronX® technology, providing superior taste, water quality, filter life longevity and peace of mind when it comes to hygiene.



994051 - (5.0 micron)

Supplied standard.
Commercial & high volume sites.



994052 - (0.2 micron)

Fine filtration.
Residential or Critical Care sites.

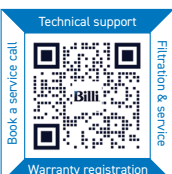

Please scan the QR code for all support information.

Billi Australia Pty Ltd
P 1800 812 321
W www.billi.com.au

Billi New Zealand Ltd
P 0800 636 0 636
W www.billi.co.nz

Billi