

#### Billi Alpine 125 with Multifunction Mixer Tap

The Alpine Chilled & Ambient (still) drinking water system, is a mid-sized commercial capacity system, that maintains Billi's core design principles of space saving and vent-free installation. Dispensing chilled or ambient temperature water on demand, with a continuous supply of cool filtered water once tank capacity is depleted, the Alpine range is convenient and highly functional in offering uninterrupted hydration.

The Good Design Award winning integrated Multifunction Mixer Tap provides a sleek solution to dispensing filtered water with a touch sensitive interface, alongside domestic mains supplied by operating a standard flick mixer.



CHILLED



STILL



Up to 40

#### Features



AUSTRALIAN  
DESIGNED  
& MADE



WATER  
COOLED  
TECHNOLOGY



SPACE SAVING  
DESIGN



VENT-FREE  
INSTALLATION



ECO-INTELLIGENCE  
ENERGY MODES



UNLIMITED  
FILTERED  
WATER

Multifunction  
Mixer Tap



Alpine 125  
Under-Bench Unit



#### Finishes

Standard Finishes



CH -  
Chrome



BR -  
Brushed



MB -  
Matte Black



MW -  
Matte White

Special Order Finishes



UB -  
Urban Brass



GM -  
Gun Metal Grey



SB -  
Sable Bronze

Add the relevant Finish Code to the Product code to complete your specification eg 932125GCH-LF

#### Accessories

**990720** - Tubing Extension Kit for X series dual temp dispensers 2mtrs

#### Product Specifications

Water Type	CA
Dispenser	G - Multifunction Mixer Tap
Mixer Tapware	N/A
Product Code	932125G
Warranty	3 years manufacturers warranty
Under-Bench Dimensions	180mm(W) x 340mm (H) x 460mm (D)
Boiling Output	N/A
Chilled Output	Up to 125 cups per hour
Sparkling Output	N/A
50°C Hot Water Output	N/A
Min / Max Dispenser Temp	6°C / 12°C
Power Plug	10 amp
Power Rating	300W, 220-240V, 50-60Hz
Water Pressure	Min. 250kPa
Ecolabel	N/A
EPD	N/A
Greenstar Contribution	N/A
Watermark License	WM-021882
Lead Free	✓
Section J7.7 (NCC)	✓
WELS	N/A
WELL	Cornerstone Membership
Management Systems	Every Billi drinking water appliance is manufactured under the strictest standards and is certified in accordance with: ISO9001 for QMS (FS 790754), ISO14001 for EMS (EMS 801468) and ISO45001 for OSHS (OHS 801469).
Food Handling	HACCP License No. PE-138-BIL-R1-02
Filtration	994051 - 5.0 Micron supplied standard

Scan the QR code access  
our Revit families on  
**bimstore**

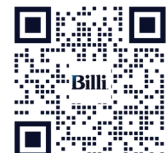

## Technical Drawings

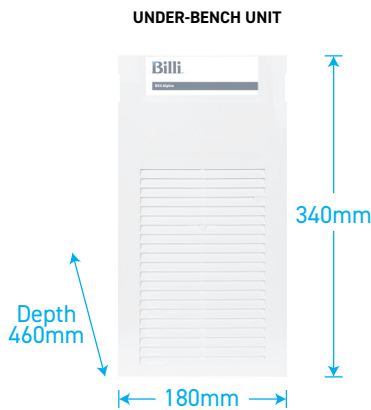
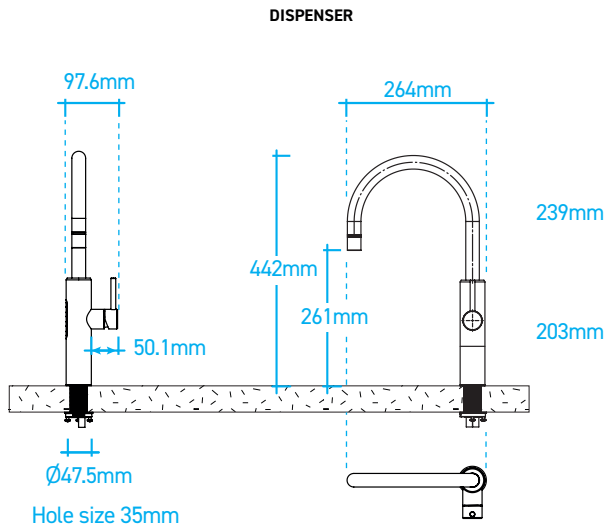

## Installation Requirements

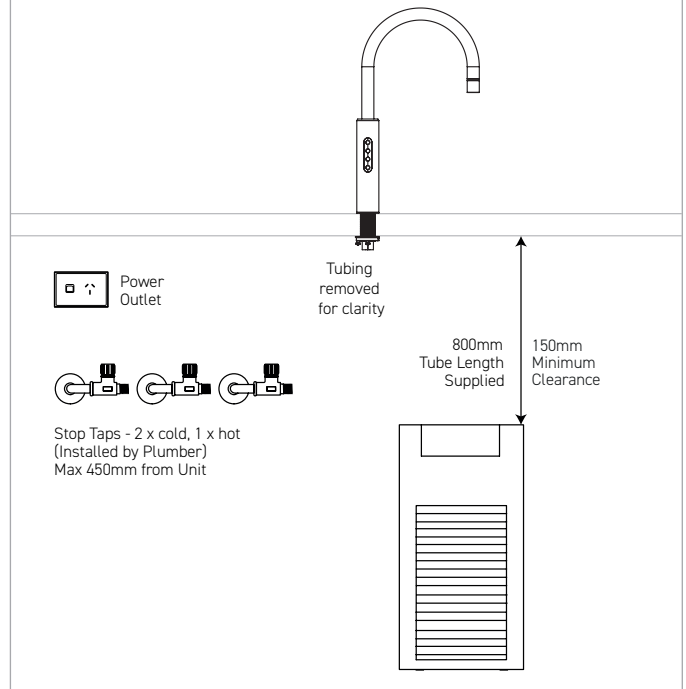

## Installation Notes

- Electrical** A standard 10 amp power outlet is required, located no further than 1000mm from the underbench unit. The system is supplied with a 1 metre flex cord and plug.
- Water** A 1 x 1/2" BSP (15mm) cold stop tap required for unit supply and 1 x 1/2" BSP hot stop tap and 1 x 1/2" BSP cold stop tap required for mixer connection with male threads and it should be installed in an easily accessible position. Water supply must be microbiologically safe to drink, with a minimum dynamic water pressure of 250kPa and a maximum of 1000kPa.
- Pressure Valve** Integrated 500kPa pressure limiting and dual check valve is pre-installed to the unit inlet.
- Stone Benches** Billi has a no-cut policy regarding all stone benches in compliance with regulations. The safety of our team and customers remains Billi's top priority.
- Ventilation** No joinery ventilation or accessories are required for this Billi product (water cooled technology).

## Filtration - Most Recommended Replacement Filters

Billi range of premium filters utilize BWT's unique FibronX® technology, providing superior taste, water quality, filter life longevity and peace of mind when it comes to hygiene.



**994051 - (5.0 micron)**

Supplied standard. Commercial & high volume sites.



**994052 - (0.2 micron)**

Fine filtration. Residential or Critical Care sites.

\* Drawings are for guidance during Specification, refer to Installation requirements for final install. All efforts are made to ensure Compliance & Certifications claims are current, however this is subject to change without notice. Billi assumes no liability or responsibility for out of date information.

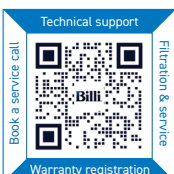

Please scan the QR code for all support information.

**Billi Australia Pty Ltd**

**P** 1800 812 321  
**W** www.billi.com.au

**Billi New Zealand Ltd**

**P** 0800 636 0 636  
**W** www.billi.co.nz

**Billi**