

Billi Eco Sparkling with XL Levered Dispenser

The Eco Sparkling is a premium drinking water solution that delivers instant boiling, chilled, and sparkling filtered water from a single appliance. Featuring underbench ice bank technology, it offers increased capacity and faster recovery, ensuring consistent performance even in high-demand settings. Designed with efficiency and convenience in mind, the Eco Sparkling combines advanced functionality with modern style.

The XL Levered dispenser is streamlined and elegant, providing boiling, chilled, and sparkling water safely and at your chosen pace through its intuitive, position-sensitive levers. Fully AS1428 compliant, it offers both accessibility and refined design.



BOILING



CHILLED



SPARKLING



Up to 10

Features



ENERGY EFFICIENT



ICE BANK TECHNOLOGY



ADJUSTABLE CHILLED TEMPERATURE



ADJUSTABLE SPARKLING LEVEL



SAFE TO OPERATE



ITALO-AUSTRALIAN PARTNERSHIP

Australian design & made Boiling unit ^ Italian design & made Sparkling unit

XL Levered Dispenser

Eco Sparkling Under-Bench Units



Finishes

Standard Finishes



CH - Chrome



BR - Brushed



MB - Matte Black



MW - Matte White

Special Order Finishes



UB - Urban Brass



GM - Gun Metal Grey



SB - Sable Bronze

Add the relevant Finish Code to the Product code to complete your specification eg 906000LCH-LF

Accessories

992800 - 70mm Riser & Font



992820 - 70mm Riser



992803 - 120mm Riser & Font



992830 - 120mm Riser



990720 - Tubing Extension Kit for X series dual temp dispensers 2mtrs

Product Specifications

| | |
|----------------------------------|--|
| Water Type | BCS |
| Dispenser | L - XL Levered Dispenser |
| Mixer Tapware | N/A |
| Product Code | 906000L |
| Warranty | 3 years manufacturers warranty |
| Under-Bench Dimensions (Boiling) | 180mm(W) x 340mm (H) x 365mm (D) |
| Under-Bench Dimensions (Cold) | 255mm(W) x 410mm (H) x 420mm (D) |
| Boiling Output | Up to 90 cups per hour |
| Chilled* Output | Up to 100 cups per hour |
| Sparkling* Output | Up to 100 cups per hour |
| 50°C Hot Water Output | N/A |
| Min / Max Dispenser Temp | 6°C / 99°C |
| Power Plug | 2 x 10 amp |
| Power Rating | 1600W, 220-240V, 50-60Hz |
| Water Pressure | Min. 250kPa |
| Ecolabel | N/A |
| EPD | N/A |
| Greenstar Contribution | N/A |
| Watermark License | WM-021525 |
| Lead Free | ✓ |
| Section J7.7 (NCC) | ✓ |
| WELS | N/A |
| WELL | Cornerstone Membership |
| Management Systems | Every Billi drinking water appliance is manufactured under the strictest standards and is certified in accordance with: ISO9001 for QMS (FS 790754), ISO14001 for EMS (EMS 801468) and ISO45001 for OSHS (OHS 801469). |
| Food Handling | HACCP - PE-138-BIL-R1-02 |
| Filtration | 994051 - 5.0 Micron supplied standard |

Scan the QR code access our Revit families on

bimstore

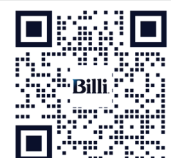

*Combined usage for Chilled and Sparkling.

Technical Drawings

DISPENSER

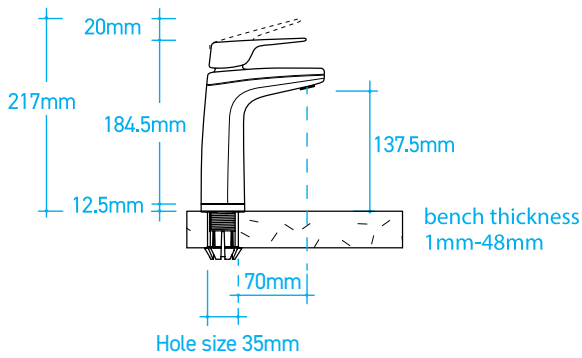

UNDER-BENCH UNITS



Installation Requirements

Please refer to Vent Kit Installation Guide - Ref. No. 611002-02

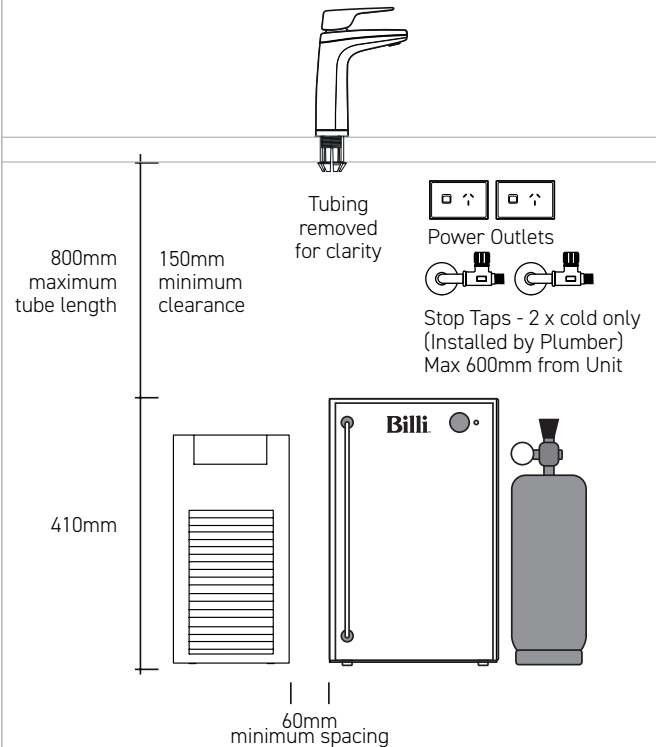

Installation Notes

Electrical

Two (2) standard 10 amp power outlets are required, located no further than 1000mm from the underbench unit. The system is supplied with a 1 metre flex cord and plug.

Water

Two (2) Cold 1/2" BSP (15mm) stop-taps with a male thread should be installed in an easily accessible position. Water supply must be microbiologically safe to drink, with a minimum dynamic water pressure of 250kPa and a maximum of 1000kPa.

Pressure Valve

Integrated 500kPa pressure limiting and dual check valve is pre-installed to the unit inlet.

CO2 MSDS

The CO₂ gas cylinder supplied must be secured in a suitable location. Each cylinder contains 1100g of CO₂ and should be installed in a well ventilated area. Each cylinder will provide between 200-350L of sparkling water depending on the unit settings. The MSDS is available on www.billi.com.au for a complete list of specifications and warnings. Replacement gas cylinders are available from Billi. CO₂ Cylinder - single 996911 or double 996912.

Stone Benches

Billi has a no-cut policy regarding all stone benches in compliance with regulations. The safety of our team and customers remains Billi's top priority.

Ventilation

This is an air cooled product, ventilation is vital under normal operating conditions. Failure to follow manufacturers ventilation recommendations can risk warranty.

Filtration - Most Recommended Replacement Filters

Billi range of premium filters utilize BWT's unique FibronX® technology, providing superior taste, water quality, filter life longevity and peace of mind when it comes to hygiene.



994051 - (5.0 micron)

Supplied standard. Commercial & high volume sites.



994052 - (0.2 micron)

Fine filtration. Residential or Critical Care sites.

*Drawings are for guidance during Specification, refer to Installation requirements for final install. All efforts are made to ensure Compliance & Certifications claims are current, however this is subject to change without notice. Billi assumes no liability or responsibility for out of date information.

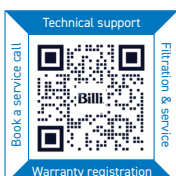

Please scan the QR code for all support information.

Billi Australia Pty Ltd

P 1800 812 321
W www.billi.com.au

Billi New Zealand Ltd

P 0800 636 0 636
W www.billi.co.nz

Billi