

Billi Eco with XL Levered Dispenser

The opening stanza for the boiling & chilled range of drinking water appliances, the Billi Eco is the pioneer in space saving, energy efficient and environmentally conscious under-bench instantaneous systems. The high performing system is specifically designed for tight spaces, servicing smaller populations requiring fast recovery.

The XL levered dispenser is streamlined and elegant, offering boiling and chilled output delivered safely and at your own pace simply by operating the position-sensitive levers.



Features



AUSTRALIAN
DESIGNED
& MADE



SPACE SAVING
DESIGN



ECO-
INTELLIGENCE
TECHNOLOGY



ENERGY
EFFICIENT



EASY
INSTALLATION



ADJUSTABLE
CHILLED
TEMPERATURE

XL Levered
Dispenser



Eco Under-Bench
Unit



Finishes

Standard Finishes



CH -
Chrome



BR -
Brushed



MB -
Matte Black



MW -
Matte White

Special Order Finishes



UB -
Urban Brass



GM -
Gun Metal Grey



SB -
Sable Bronze

Add the relevant Finish Code to the Product code to complete your specification eg 901000LCH-LF

Accessories

992800 - 70mm Riser & Font



992820 - 70mm Riser



992803 - 120mm Riser & Font



992830 - 120mm Riser



990720 - Tubing Extension Kit for X series dual temp dispensers 2mtrs

Product Specifications

Water Type	BC
Dispenser	L - XL Levered Dispenser
Mixer Tapware	N/A
Product Code	901000L
Warranty	3 years manufacturers warranty
Under-Bench Dimensions	180mm(W) x 340mm (H) x 500mm (D)
Boiling Output	Up to 90 cups per hour
Chilled Output	Up to 60 cups per hour
Sparkling Output	N/A
50°C Hot Water Output	N/A
Min / Max Dispenser Temp	6°C / 99°C
Power Plug	10 amp
Power Rating	1600W, 220-240V, 50-60Hz
Water Pressure	Min. 250kPa
Ecolabel	N/A
EPD	N/A
Greenstar Contribution	N/A
Watermark License	WM-021525
Lead Free	✓
Section J7.7 (NCC)	✓
WELS	N/A
WELL	Cornerstone Membership
Management Systems	Every Billi drinking water appliance is manufactured under the strictest standards and is certified in accordance with: ISO9001 for QMS (FS 790754), ISO14001 for EMS (EMS 801468) and ISO45001 for OSHS (OHS 801469).
Food Handling	HACCP - PE-138-BIL-R1-02
Filtration	994051 - 5.0 Micron supplied standard

Scan the QR code access
our Revit families on
bimstore



Technical Drawings

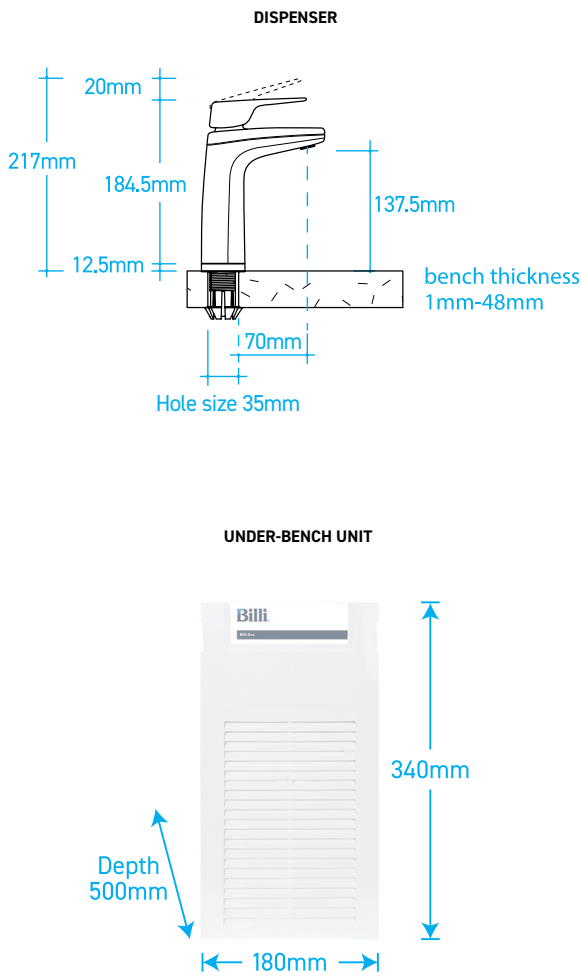

*Drawings are for guidance during Specification, refer to Installation requirements for final install. All efforts are made to ensure Compliance & Certifications claims are current, however this is subject to change without notice. Billi assumes no liability or responsibility for out of date information.

Installation Requirements

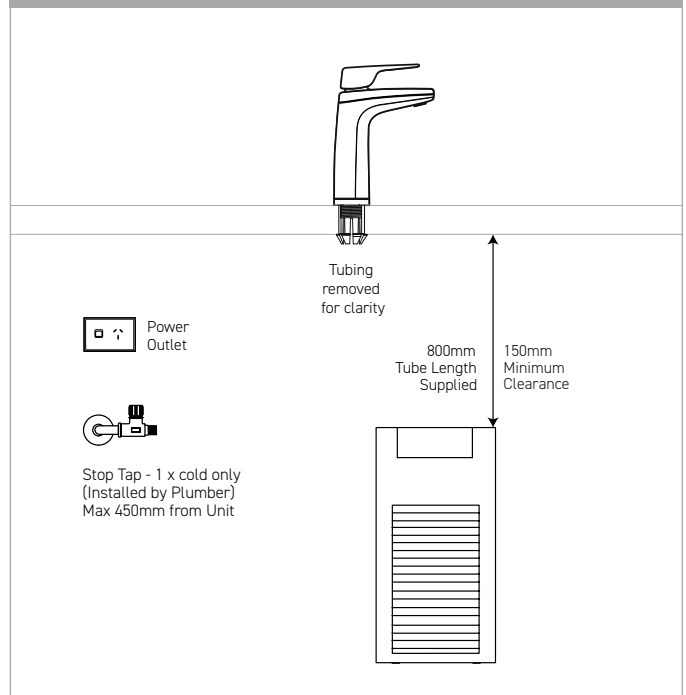

Installation Notes

Electrical	A standard 10 amp power outlet is required, located no further than 1000mm from the underbench unit. The system is supplied with a 1 metre flex cord and plug.
Water	A single 1/2" BSP (15mm) stop-tap with a male thread should be installed in an easily accessible position. Water supply must be microbiologically safe to drink, with a minimum dynamic water pressure of 250kPa and a maximum of 1000kPa.
Pressure Valve	Integrated 500kPa pressure limiting and dual check valve is pre-installed to the unit inlet.
Stone Benches	Billi has a no-cut policy regarding all stone benches in compliance with regulations. The safety of our team and customers remains Billi's top priority.
Ventilation	The Eco requires some cupboard ventilation and adequate air space as well as an unobstructed clearance of at least 100mm on each side of the underbench unit. Insufficient ventilation will cause inefficient refrigeration system operation, increasing power usage and potential failure.

Filtration – Most Recommended Replacement Filters

Billi range of premium filters utilize BWT's unique FibronX® technology, providing superior taste, water quality, filter life longevity and peace of mind when it comes to hygiene.

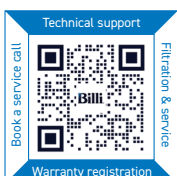

Please scan the QR code for all support information.

Billi Australia Pty Ltd
P 1800 812 321
W www.billi.com.au

Billi New Zealand Ltd
P 0800 636 0 636
W www.billi.co.nz

Billi