

Billi Sahara 320 with Safety Dispenser

The Sahara Boiling and Ambient (still) drinking water system, is a commercial capacity system, that maintains Billi's core design principles of space saving and vent-free installation. Offering both boiling temperature water and a bottomless supply of filtered ambient temperature water, the Sahara range is convenient and highly functional.

The Safety Dispenser was designed in consultation with industry experts and is widely regarded as the best fit-for-purpose solution currently available. Ideal for high security or critical care environments, including correctional facilities and mental health care units.



BOILING



STILL



Features



AUSTRALIAN
DESIGNED
& MADE



SPACE SAVING
DESIGN



VENT-FREE
INSTALLATION



ECO-INTELLIGENCE
ENERGY MODES



UNLIMITED
FILTERED
WATER



EASY
INSTALLATION

Safety
Dispenser



Sahara 320
Under-Bench Unit



Finishes

Standard Finish



CH - Chrome

Add the relevant Finish Code to the Product code to complete your specification eg 943020VCH-LF

Accessories

990718CH - QL Font for Safety Dispenser



990720 - Tubing Extension Kit for X series dual temp dispensers 2mtrs

Product Specifications

Water Type	BA
Dispenser	V - Safety Dispenser
Mixer Tapware	N/A
Product Code	943020V
Warranty	3 years manufacturers warranty
Under-Bench Dimensions	180mm(W) x 340mm (H) x 460mm (D)
Boiling Output	Up to 90 cups per hour
Chilled Output	N/A
Sparkling Output	N/A
50°C Hot Water Output	N/A
Min / Max Dispenser Temp	Ambient / 99°C
Power Plug	10 amp
Power Rating	1600W, 220-240V ~ 50-60Hz
Water Pressure	Min. 250kPa
Ecolabel	N/A
EPD	N/A
Greenstar Contribution	N/A
Watermark License	WM-021525
Lead Free	✓
Section J7.7 (NCC)	✓
WELS	N/A
WELL	Cornerstone Membership
Management Systems	Every Billi drinking water appliance is manufactured under the strictest standards and is certified in accordance with: ISO9001 for QMS (FS 790754), ISO14001 for EMS (EMS 801468) and ISO45001 for OSHS (OHS 801469).
Food Handling	HACCP License No. PE-138-BIL-R1-02
Filtration	994051 - 5.0 Micron supplied standard

Scan the QR code access
our Revit families on
bimstore

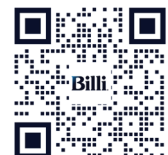

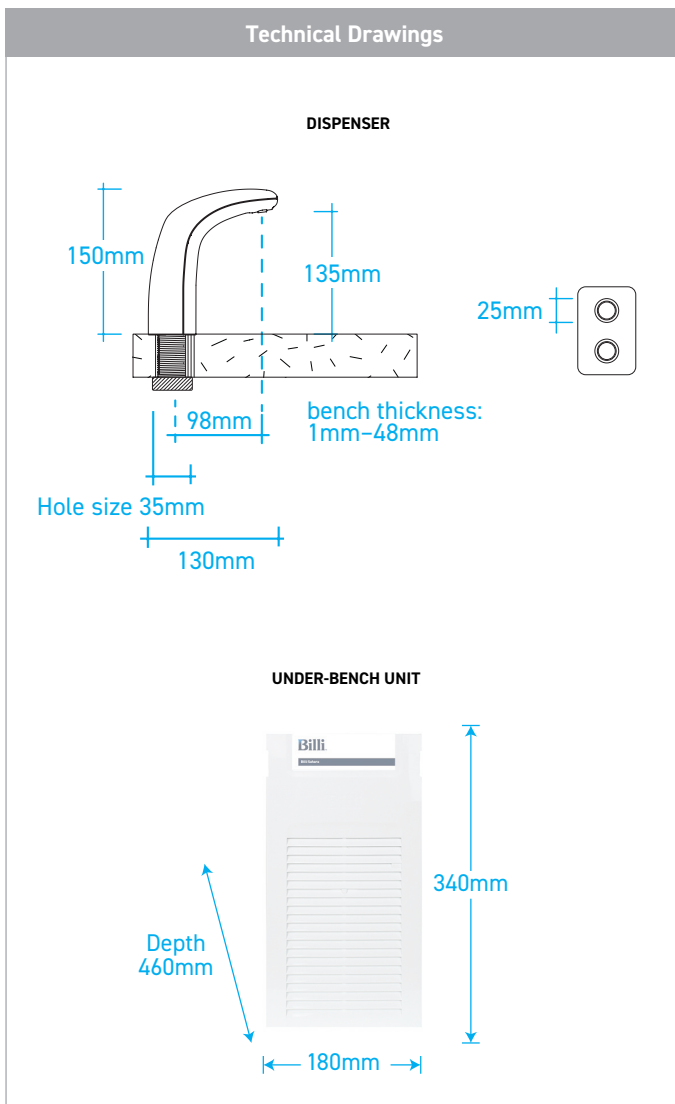

* Drawings are for guidance during Specification, refer to Installation requirements for final install. All efforts are made to ensure Compliance & Certifications claims are current, however this is subject to change without notice. Billi assumes no liability or responsibility for out of date information.

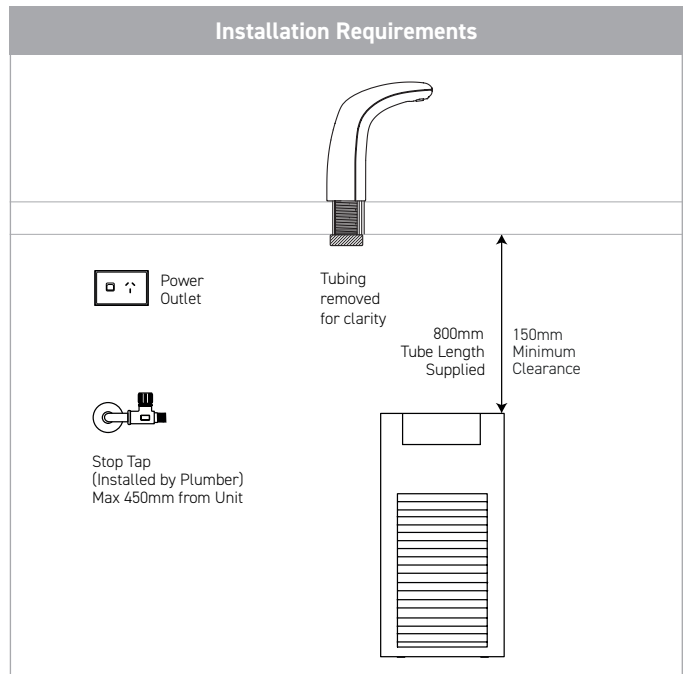

Installation Notes

- Electrical** A standard 10 amp power outlet is required, located no further than 1000mm from the underbench unit. The system is supplied with a 1 metre flex cord and plug.
- Water** A single 1/2" BSP (15mm) stop-tap with a male thread should be installed in an easily accessible position. Water supply must be microbiologically safe to drink, with a minimum dynamic water pressure of 250kPa and a maximum of 1000kPa.
- Pressure Valve** Integrated 500kPa pressure limiting and dual check valve is pre-installed to the unit inlet.
- Stone Benches** Billi has a no-cut policy regarding all stone benches in compliance with regulations. The safety of our team and customers remains Billi's top priority.
- Ventilation** No joinery ventilation or accessories are required for this Billi product (no waste heat).

Filtration – Most Recommended Replacement Filters

Billi range of premium filters utilize BWT's unique FibronX® technology, providing superior taste, water quality, filter life longevity and peace of mind when it comes to hygiene.

994051 - (5.0 micron)

Supplied standard. Commercial & high volume sites.

994052 - (0.2 micron)

Fine filtration. Residential or Critical Care sites.



Technical support

Book a service call

Filteration & service

Warranty registration

Please scan the QR code for all support information.

Billi Australia Pty Ltd
P 1800 812 321
W www.billi.com.au

Billi New Zealand Ltd
P 0800 636 0 636
W www.billi.co.nz

