

Billi Sahara Plus 3120 with Safety Dispenser & Gooseneck Mixer

The Sahara Boiling and Ambient (still) drinking water system, is a commercial capacity system, that maintains Billi's core design principles of space saving and vent-free installation. Offering both boiling temperature water and a bottomless supply of filtered ambient temperature water, the Sahara range is convenient and highly functional.

This system also serves as a point of use hot water system, for tea preps and breakout spaces with the addition of a mixer tap, providing Hot and Cold water for the sink.

The Safety Dispenser was designed in consultation with industry experts and is widely regarded as the best fit-for-purpose solution currently available. Ideal for high security or critical care environments, including correctional facilities and mental health care units.

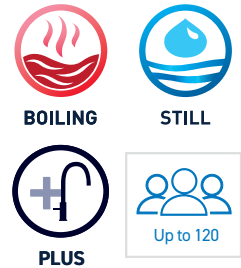

Features



AUSTRALIAN
DESIGNED
& MADE



SPACE SAVING
DESIGN



VENT-FREE
INSTALLATION



ECO-
INTELLIGENCE
ENERGY MODE



UNLIMITED
FILTERED
WATER



EASY
INSTALLATION

Safety
Dispenser



Gooseneck
Mixer



Sahara Plus 3120
Under-Bench Unit



Finishes

Standard Finish



CH - Chrome

Add the relevant Finish Code to the Product code to complete your specification, eg. 943125VGCH-LF

Accessories

990718CH - QL Font for Safety Dispenser



990720 - Tubing Extension Kit for X series dual temp dispensers 2mtrs

Product Specifications

Water Type	BAHA
Dispenser	V - Safety Dispenser
Mixer Tapware	G - Gooseneck Mixer
Product Code	943125VG
Warranty	3 years manufacturers warranty
Under-Bench Dimensions	180mm(W) x 340mm (H) x 460mm (D)
Boiling Output	Up to 220 cups per hour
Chilled Output	N/A
Sparkling Output	N/A
50°C Hot Water Output	Up to 65L per hour
Min / Max Dispenser Temp	Ambient / 99°C
Power Plug	15 amp
Power Rating	3400W, 220-240V ~ 50-60Hz
Water Pressure	Min. 250kPa
Ecolabel	N/A
EPD	N/A
Greenstar Contribution	N/A
Watermark License	WM-021525 (unit), WM-25901 (tap)
Lead Free	✓
Section J7.7 (NCC)	✓
WELS	6 Star - T29499
WELL	Cornerstone Membership
Management Systems	Every Billi drinking water appliance is manufactured under the strictest standards and is certified in accordance with: ISO9001 for QMS (FS 790754), ISO14001 for EMS (EMS 801468) and ISO45001 for OSHS (OHS 801469).
Food Handling	HACCP License No. PE-138-BIL-R1-02
Filtration	994051 - 5.0 Micron supplied standard

Scan the QR code access
our Revit families on
bimstore

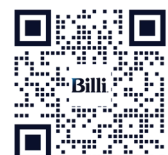

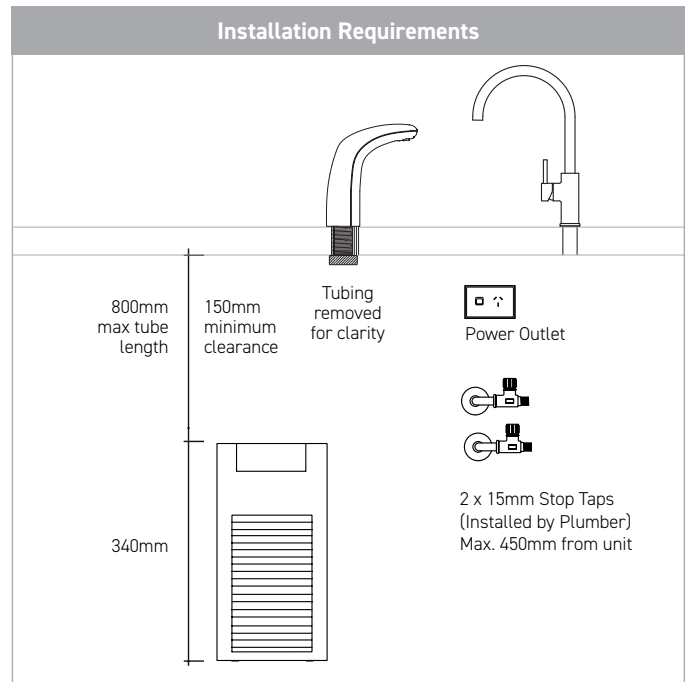
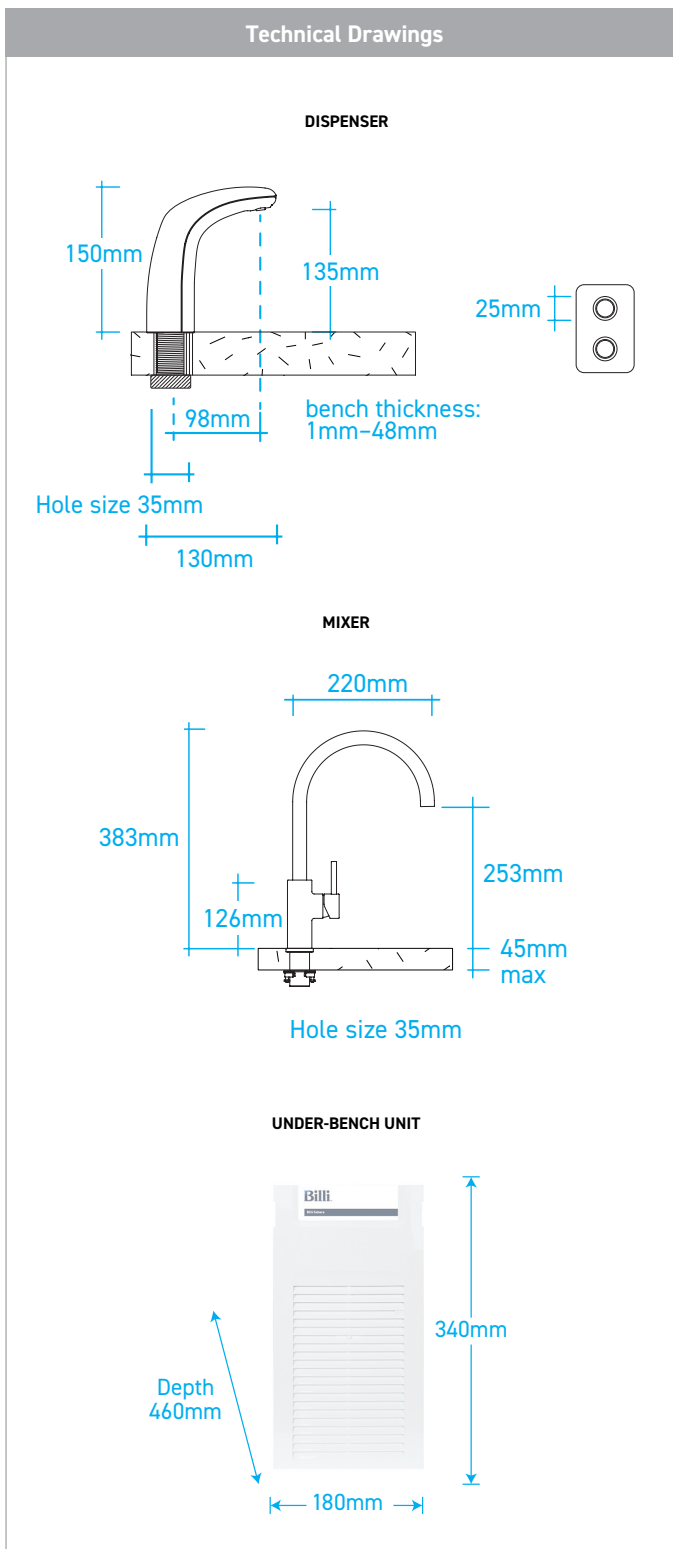

Installation Notes

- Electrical** A standard 15 amp power outlet is required, located no further than 1000mm from the underbench unit. The system is supplied with a 1 metre flex cord and plug.
- Water** Two (2) Cold 1/2" BSP (15mm) stop-taps with a male thread should be installed in an easily accessible position. Water supply must be microbiologically safe to drink, with a minimum dynamic water pressure of 250kPa and a maximum of 1000kPa.
- Pressure Valve** Integrated 500kPa pressure limiting and dual check valve is pre-installed to the unit inlet.
- Stone Benches** Billi has a no-cut policy regarding all stone benches in compliance with regulations. The safety of our team and customers remains Billi's top priority.
- Ventilation** No joinery ventilation or accessories are required for this Billi product (no waste heat).

Filtration – Most Recommended Replacement Filters

Billi range of premium filters utilize BWT's unique FibronX® technology, providing superior taste, water quality, filter life longevity and peace of mind when it comes to hygiene.

994051 - (5.0 micron)

Supplied standard. Commercial & high volume sites.

994052 - (0.2 micron)

Fine filtration. Residential or Critical Care sites.

*Drawings are for guidance during Specification, refer to Installation requirements for final install. All efforts are made to ensure Compliance & Certifications claims are current, however this is subject to change without notice. Billi assumes no liability or responsibility for out of date information



Technical support

Book a service call

Filtration & service

Warranty registration

Please scan the QR code for all support information.

Billi Australia Pty Ltd
P 1800 812 321
W www.billi.com.au

Billi New Zealand Ltd
P 0800 636 0 636
W www.billi.co.nz

