

#### Billi Sahara Plus 320 with XT Touch Dispenser & Paddle Mixer

The Sahara Boiling and Ambient (still) drinking water system, is a commercial capacity system, that maintains Billi's core design principles of space saving and vent-free installation. Offering both boiling temperature water and a bottomless supply of filtered ambient temperature water, the Sahara range is convenient and highly functional.

This system also serves as a point of use hot water system, for tea preps and breakout spaces with the addition of a mixer tap, providing Hot and Cold water for the sink.

The XT touch dispenser is an innovative, contemporary design, which has a top operating panel offering a sophisticated and clean style.

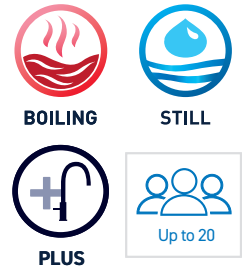

#### Features



XT Touch Dispenser

Paddle Mixer

Sahara Plus 320 Under-Bench Unit



#### Finishes

##### Standard Finishes



Add the relevant Finish Code to the Product code to complete your specification, eg. 943025TPCH-LF

#### Accessories

992800 - 70mm Riser & Font



992820 - 70mm Riser



992803 - 120mm Riser & Font



992830 - 120mm Riser



990720 - Tubing Extension Kit for X series dual temp dispensers 2mtrs

#### Product Specifications

Water Type	BAHA
Dispenser	T - XT Touch Dispenser
Mixer Tapware	P - Paddle Mixer
Product Code	943025TP
Warranty	3 years manufacturers warranty
Under-Bench Dimensions	180mm(W) x 340mm (H) x 460mm (D)
Boiling Output	Up to 120 cups per hour
Chilled Output	N/A
Sparkling Output	N/A
50°C Hot Water Output	Up to 25L per hour
Min / Max Dispenser Temp	Ambient / 99°C
Power Plug	10 amp
Power Rating	1600W, 220-240V ~ 50-60Hz
Water Pressure	Min. 250kPa
Ecolabel	N/A
EPD	N/A
Greenstar Contribution	N/A
Watermark License	WM-021525 (unit), WM-25901 (tap)
Lead Free	✓
Section J7.7 (NCC)	✓
WELS	6 Star - T29340
WELL	Cornerstone Membership
Management Systems	Every Billi drinking water appliance is manufactured under the strictest standards and is certified in accordance with: ISO9001 for QMS (FS 790754), ISO14001 for EMS (EMS 801468) and ISO45001 for OSHS (OHS 801469).
Food Handling	HACCP License No. PE-138-BIL-R1-02
Filtration	994051 - 5.0 Micron supplied standard

Scan the QR code access our Revit families on

**bimstore**

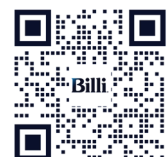

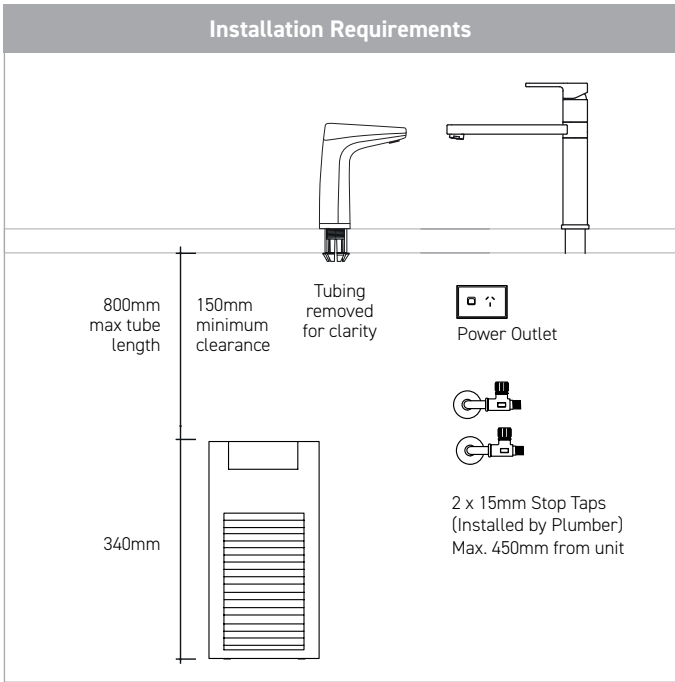
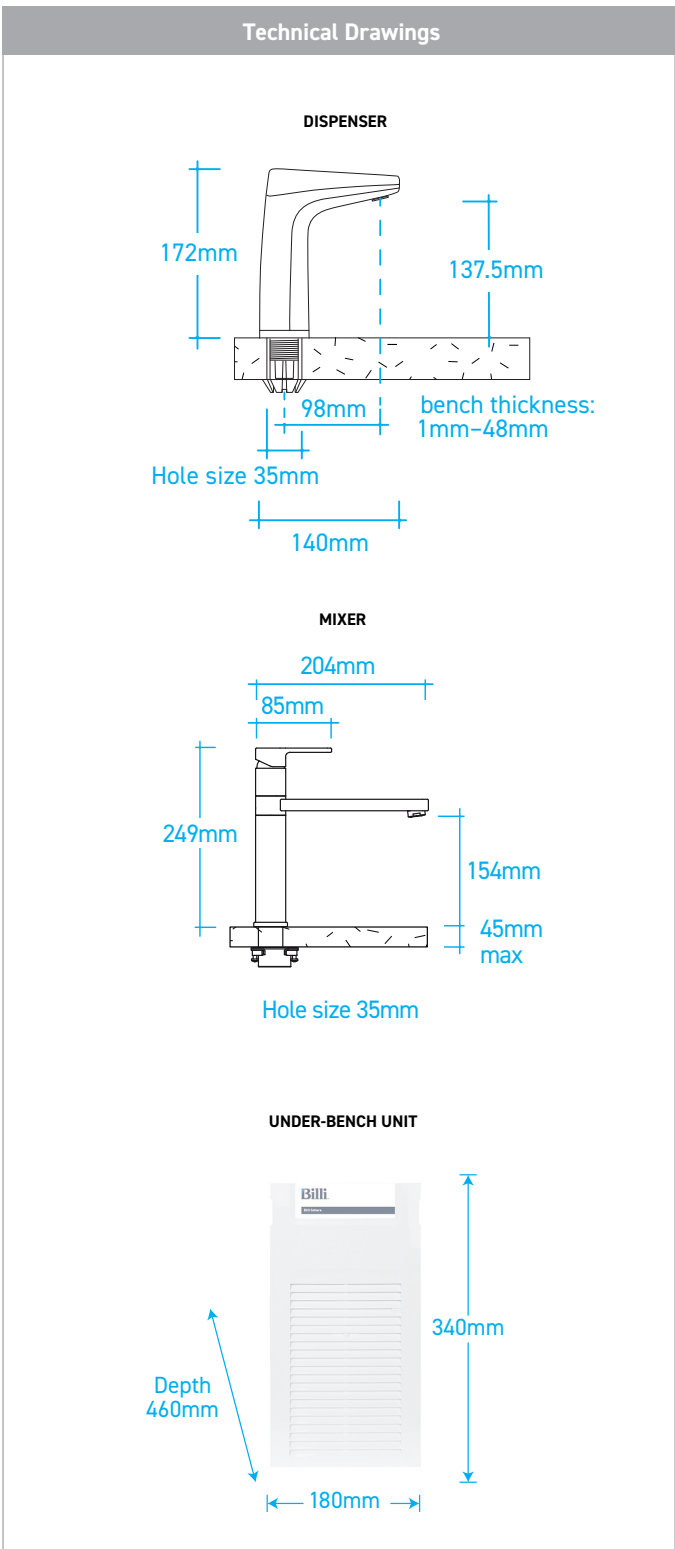

### Installation Notes

- Electrical** A standard 10 amp power outlet is required, located no further than 1000mm from the underbench unit. The system is supplied with a 1 metre flex cord and plug.
- Water** Two (2) Cold 1/2" BSP (15mm) stop-taps with a male thread should be installed in an easily accessible position. Water supply must be microbiologically safe to drink, with a minimum dynamic water pressure of 250kPa and a maximum of 1000kPa.
- Pressure Valve** Integrated 500kPa pressure limiting and dual check valve is pre-installed to the unit inlet.
- Stone Benches** Billi has a no-cut policy regarding all stone benches in compliance with regulations. The safety of our team and customers remains Billi's top priority.
- Ventilation** No joinery ventilation or accessories are required for this Billi product (no waste heat).

### Filtration – Most Recommended Replacement Filters

Billi range of premium filters utilize BWT's unique FibronX® technology, providing superior taste, water quality, filter life longevity and peace of mind when it comes to hygiene.



**994051 - (5.0 micron)**

Supplied standard.  
Commercial & high volume sites.



**994052 - (0.2 micron)**

Fine filtration.  
Residential or Critical Care sites.

\*Drawings are for guidance during Specification, refer to Installation requirements for final install. All efforts are made to ensure Compliance & Certifications claims are current, however this is subject to change without notice. Billi assumes no liability or responsibility for out of date information



Technical support

Book a service call



Filteration & service

Warranty registration

Please scan the QR code for all support information.

**Billi Australia Pty Ltd**

P 1800 812 321

W [www.billi.com.au](http://www.billi.com.au)

**Billi New Zealand Ltd**

P 0800 636 0 636

W [www.billi.co.nz](http://www.billi.co.nz)

