

Commercial Installation Guide

Billi OmniOne Pro20 (926020)
Billi OmniOne Pro60 (926060)
Billi OmniOne Pro Plus 9 (926065)

XL, XT Motion, Multifunction
Mixer Tap, & Plus Mixer Tap



CONTENTS

Warnings and Important Information	3
Unpacking your Billi OmniOne	4
Included Components	4
Installation Requirements	4
Installation Requirements cont.	5
Installing the XL & XT Motion	6
Installing the XL Dispenser cont.	8
Installing the MMT Dispenser	9
Installing Underbench Module	11
Installing the Plus Mixer Tap (Billi OmniOne Plus Models Only)	13
Installing Underbench Module	15
Commissioning	16
Installation and Commission Checklist	17

Warnings and Important Information

- For continued safety of this appliance, it must be installed, operated and maintained in accordance with the manufacturer's instructions.
- Your appliance should be installed by the manufacturer, a service agent, or any other suitably qualified tradesperson.
- For correct operation of this appliance it is essential to observe the instructions as outlined in this booklet.
- Do not use this appliance with water that is microbiologically unsafe or with water of unknown quality without adequate disinfection before or after the system. Systems certified for cyst reduction may be used on disinfected water that may contain filterable cysts.
- Filter replacement must be performed at intervals of not more than 12 months.
- Use this appliance only as directed in these instructions and only for its designed purpose.
- This appliance is not intended for use by persons (including children) with reduced physical, sensory or mental capabilities, or persons with lack of experience and knowledge, unless they are supervised or have been given instruction concerning use by a person responsible for their safety.
- This appliance is not to be installed in an area where a water jet could be used.
- Children should be supervised to ensure that they do not play with the appliance.
- **DANGER:** The operation of the flange mounted thermal cut-out indicates a possibly dangerous situation. Do not reset the thermal cut-out until the appliance has been serviced by a suitably qualified person.
- **WARNING:** Do not connect any restrictor, pressure relief device or non-return valve to the vent pipe of this appliance.
- **WARNING:** When positioning the appliance ensure the power supply cord is not trapped or damaged.
- **WARNING:** Do not install the appliance using a power board, double power adaptor or any other similar device. The appliance is to be plugged directly into a suitably protected and rated power point.
- **WARNING:** If the power supply cord is damaged, it must be replaced by the manufacturer, its service agent, or similarly qualified persons. The appliance is not to be used until the power supply cord is repaired.
- **WARNING:** Avoid spillages of any kind on all electrical connectors.
- **WARNING:** Potential injury can result from misuse.
- **WARNING:** Internal surfaces adjacent to and directly in contact with the heating element are subject to residual heat after use.
- Only Billi hose and tube kits as supplied with the appliance are to be used. Old or other manufacturer's hose and tube kits should not be used.
- **WARNING:** This appliance may deliver water at high temperature. Refer to the plumbing code of Australia (PCA), local requirements and installation instructions to determine if additional temperature control is required.
- **WARNING:** Installation shall conform to the plumbing code of Australia (PCA) or relevant local requirements.
- If the appliance is installed in a location where the ambient air temperature could fall below 4°C, do not turn off power to the appliance to prevent malfunction. This safeguard does not offer protection to connecting pipework and fittings external to the appliance.
- The appliance is designed to operate in an ambient air temperature range of 5°C to 30°C.
- Turn off power to the appliance by unplugging the power cord from the connected power point. Only do so after the inlet water supply has been turned off.
- The appliance is intended to be used in commercial and similar applications such as:
 - Staff kitchen areas in shops, offices, and other working environments.
 - By clients in hotels, motels, and other residential type environments.
 - Bed and breakfast type environments.
 - Catering and similar non-retail applications.
- **Please note maximum inlet water pressure is 1000kPa.**

Unpacking your Billi OmniOne

Before commencing installation, carefully check for any damage to cartons, appliance metalwork, pipework fittings and electrical power cord. If damage is found, please photograph and record details for use if a claim is to be made.

Included Components

Before commencing installation, identify the following components:

1. Underbench unit
2. Pre-installed filter cartridge
3. Dispenser kit
4. Plus mixer tap kit (Billi OmniOne Plus 9 only)
5. Power cable
6. Installation kit containing:
 - a. Drain tube assembly
 - b. 600mm flexible braided hose
 - c. Black Ø6mm PE tube
 - d. Drain connection kit containing:
 - i. Instruction sheet
 - ii. Hex key
 - iii. Drain boot
 - iv. Drain adaptor
 - v. Drain clamp
 - vi. Spring clamps x3
7. Manual kit containing:
 - a. User guide
 - b. Installation guide
 - c. Caution label
 - d. New purchase information sheet
 - e. Warranty sheet

Installation Requirements

Determine Unit Location

Plan the installation carefully, taking into consideration dispenser tube lengths, position of power and water outlets, and access for servicing. The Billi OmniOne is to be installed indoors only and must be installed on a level surface with the display panel facing to the front of the cupboard. Refer to Diagram 1 for a typical installation scenario.

A minimum cupboard depth of 520mm required for installation. No cupboard ventilation is required, however a small air gap of 10mm around each side is recommended. 150mm of clearance is recommended above the appliance for accessibility.

Power Requirements

A 10 amp single 3 pin GPO is required within the cupboard. A dedicated circuit should be provided and must be fitted with an earth leakage protection device (RCD). An externally fitted RCD device is acceptable.

Water Supply

The Billi OmniOne must only be connected to a cold water supply. A 1/2" BSP stop tap (not supplied) is to be installed in an easily accessible location within 600mm of the Billi OmniOne water supply inlet. A certified pressure limiting valve with internal dual check valve for backflow prevention is incorporated in the appliance. Do not fit an additional pressure limiting valve or dual check valve. A second 1/2" BSP water supply with stop tap is also required for Billi OmniOne Plus Models.

For OmniOne combined with Multifunction Mixer Tap, access to a 1/2" BSP hot water supply with stop tap is required.

Inlet water supply requirements:

Dynamic pressure: Min. 250kPa – Max. 1000kPa Water temperature cold: Min. 5°C – Max. 30°C

Do not install with water that is microbiologically unsafe or with water of unknown quality without adequate disinfection before or after the system. Systems certified for cyst reduction may be used on disinfected water that may contain filterable cysts.

Drainage

The Billi OmniOne requires a drainage point, such as a dishwasher nipple. Use the supplied drain boot to connect to a dishwasher nipple, or the supplied clamp- on drain adaptor to connect directly to a waste pipe. The clamp-on drain adaptor must be installed above the water seal on the sink side of the water trap.

Installation Footprint

The Billi OmniOne has the following dimensions:

Height	Width	Depth
355mm	395mm	495mm

Installation Requirements cont.

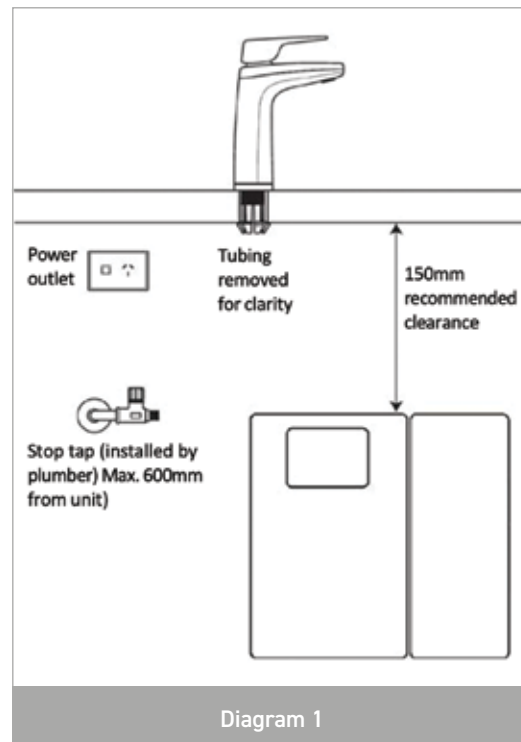

Warning: All underbench modules are pre-set to pair with XL dispensers. For Multi-function Mixer Taps, settings would need to be adjusted manually.

Installing the XL & XT Motion Dispenser

IMPORTANT: This Billi appliance is to be installed by a licensed tradesperson in accordance with AS/NZS 3500.1 and AS/NZ 3500.2 and in compliance with applicable state regulatory requirements. For the correct operation of this appliance, it is essential to observe the manufacturer's instructions.

Components in Dispenser Kit

Before commencing installation, identify the following components:

1. Dispenser
2. Large D-washer

1. Determine Dispenser Location

The dispenser can be installed on a surface 1mm –48mm thick and requires a hole size of $\varnothing 35$ mm. All tube and signal cable lengths are 800mm and connect to top rear of underbench module.

For XT Motion, ensure to leave min. 60mm for the safety lock button on rear of dispenser head. Also, ensure 60mm clearance on each side of the dispenser lens.

For XL, ensure to leave sufficient room (Min. 20mm) for the safety lock button on rear of dispenser head. Minimum flat surface area of 55mm diameter required for proper seal of tap base, refer to diagram 2. Refer to diagram 3 for dimensions of the dispenser.

2. Cut $\varnothing 35$ mm Hole in Sinktop or Benchtop

a. Stainless Steel Sinktop

A suitable $\varnothing 35$ mm hole punch (Part no: 857901) is available as an accessory from Billi Australia Pty Ltd. If possible, cut hole with die mounted below the sinktop surface so burrs are pulled downwards. Alternatively, remove burrs and radius edge of hole with a fine file.

b. Timber/Laminate Benchtop

Take care to avoid large chips breaking as the drill breaks through underside surface. We recommend drilling a small pilot hole through the benchtop, partially drilling $\varnothing 35$ mm hole from underneath, and then completing drilling hole from above.

*For all stone benchtops we recommend you use a certified stone mason to pre-drill the hole.

3. Prepare Dispenser Base Assembly for Installation

- a. Remove retaining screw on rear back of dispenser using supplied hex key.
- b. Turn dispenser base 30° then pull down to separate completely from main body, sliding over tubes and power cord. Refer to Diagram 4 and 5.
- c. Place the main body aside.
- d. Activate dispenser swivel feature if desired by pushing out locking piece as shown in Diagram 6.
- e. Remove base casting from barbed mounting shaft by unscrewing locking nut.
- f. Position critical locking sleeve at base of barbed mounting shaft, ensuring it contacts the moulded stop. Refer to Diagram 7.
- g. Push the barbed mounting shaft through underside of mount hole with barb facing down. A large D-washer is recommended to be used if there is room.
 - i. Insert D-washer over barbed mounting shaft prior to insertion through bench if it is used. Refer to Diagram 7.
- h. Re-assemble base casting and locking nut with barbed mounting shaft. Take care to align flat face on barbed mounting shaft with flat face in hole of base casting.
- i. Finger tighten the locking nut.
- j. CHECK CRITICAL LOCKING SLEEVE IS STILL POSITIONED AT BASE OF BARBED MOUNTING SHAFT.**
- k. Ensure barbs are centered in mount hole and alignment of base is correct. Moderately tighten the locking nut using multigrips or spanner. Avoid overtightening the locking nut to avoid damaging the barbed mounting shaft. Refer to Diagram 8.

4. Install Dispenser Main Body

- Feed all tubing and power cord through holes in the dispenser base. The feed power cord is first followed by tubes. Refer to Diagram 9.
- Gently pull all tubes and power cords, ensuring tubes aren't kinked or twisted. Do not attempt to force tubing or power cord through with a pointed object as this may cause damage.
- Re-assemble dispenser base and main body by turning main body 30° in relation to dispenser base and pushing down. Gently pull tubing and power cord downwards at the same time from underneath to prevent kinking and bunching.
- Turn dispenser main body straight once fully inserted and re-install retaining screw on rear back of dispenser.
- If swivel feature has been activated check dispenser now smoothly swivels 45° in each direction.

Dispenser base XL

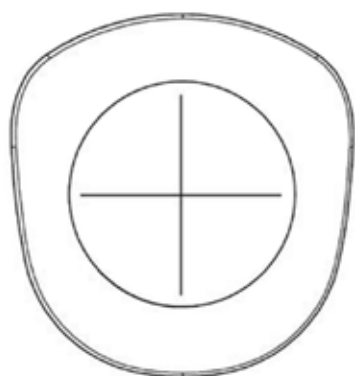

Diagram 2.1

Dispenser base XT Motion

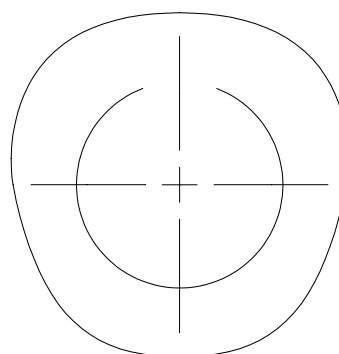

Diagram 2.2

XL Dispenser

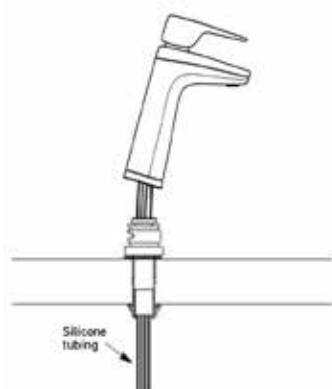

Diagram 3.1

XT Motion Dispenser

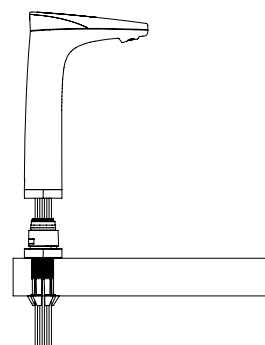
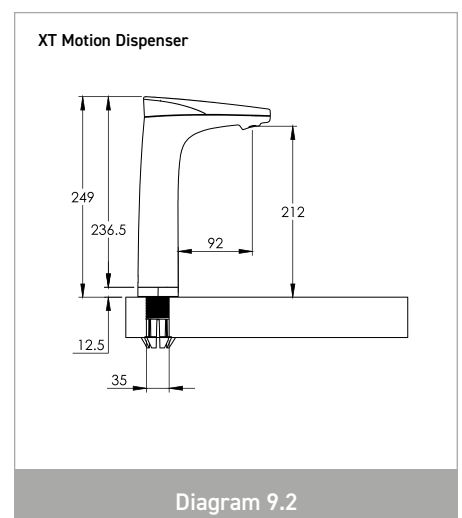
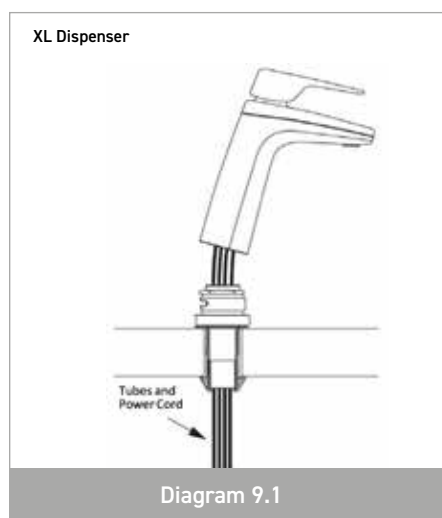
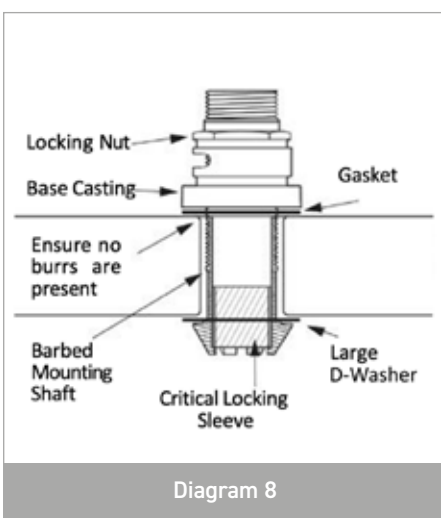
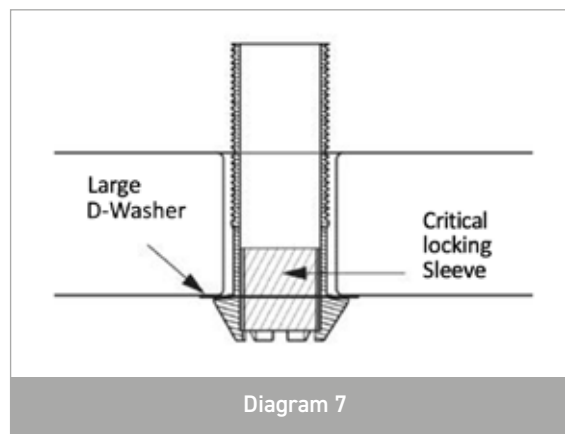
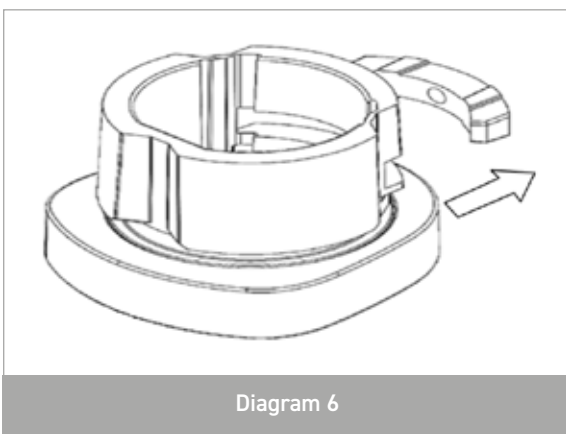
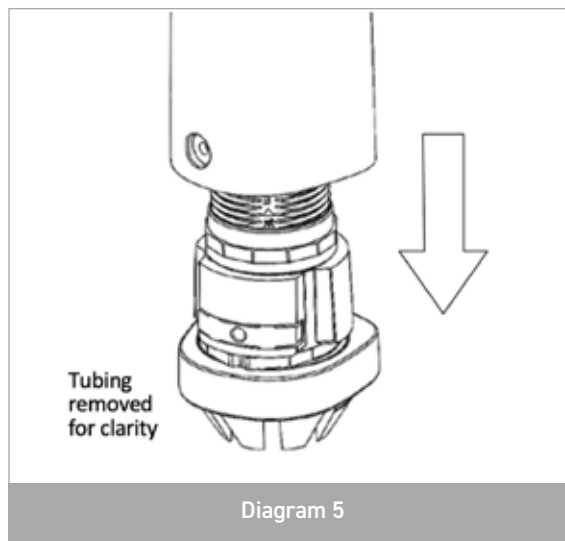
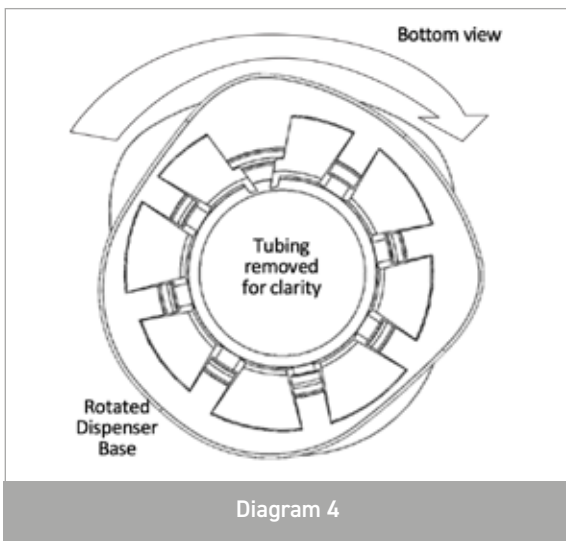

Diagram 3.2

Installing the XL Dispenser cont.



Installing the MMT Dispenser

WARNING: All underbench modules are pre-set to pair automatically with XL dispensers. For Multi-function Mixer Taps, settings need to be adjusted manually.

IMPORTANT: This Billi appliance is to be installed by a licensed tradesperson in accordance with AS/NZS 3500.1 and AS/NZ 3500.2 and in compliance with applicable state regulatory requirements. For the correct operation of this appliance, it is essential to observe the manufacturer's instructions.

Components in Dispenser Kit

Before commencing installation, identify the following components:

1. Dispenser
2. Stainless steel braided hose -Cold
3. Stainless steel braided hose -Hot
4. Collar face plate/washer
5. Mount collar with locking screws
6. Installer notification sheet

1. Determine Dispenser Location

The MMT dispenser can be installed on a surface 1mm –48mm thick and requires a hole size of $\varnothing 35\text{mm}$. All tube and signal cable lengths are 800mm and connect to the top rear of underbench module.

Refer to Diagram 11 for a base measurements for reference to minimum clearance distances and Diagram 12 for dimensions of dispenser. Ensure room for the mixer handle to operate.

2. Cut $\varnothing 35\text{mm}$ Hole in Sink top or Benchtop

a. Stainless Steel Sink top

We recommend cutting the hole with the die mounted below the sink top surface so burrs are pulled downwards.

Alternatively, remove burrs and radius edge of hole with a fine file. A suitable $\varnothing 35\text{mm}$ hole punch (Part no: 857901) is available as an accessory from Billi.

b. Timber/Laminate Benchtop

Take care to avoid a large chip breaking as the drill breaks through the underside surface. We recommend drilling a small pilot hole through the benchtop, partially drilling $\varnothing 35\text{mm}$ hole from underneath, and then completing the drilling hole from above.

*For all stone benchtops we recommend you use a certified stone mason to pre-drill the hole.

3. Prepare MMT Mixer Tap Base for Installation

- a. Remove the ring bracket located underneath the MMT tap assembly by turning it counterclockwise. Refer to Diagram 13.
- b. Set the ring bracket aside in a safe location.
- c. Connect the flexi hoses to the MMT base. Make sure that the hot flex tube connects the "H" marked fitting on the tap and cold flex hose connects the "C" marked fitting on the tap.
- d. Ensure the tubing is straightened and free from kinks before proceeding.

4. Install Dispenser Main Body

- a. Insert the MMT Mixer Tap into the mounting hole on the benchtop, ensuring all tubes and power cords are fed through the hole without bending or twisting. Refer to Diagram 14.
- b. Align the collar face plate with the mounting collar from underneath the bench and screw the mounting collar onto the mounting shaft and secure it by turning clockwise until finger tight. Refer to Diagram 15.
- c. Straighten the tap assembly and ensure it is centered in the mount hole.
- d. Using a Philips head screwdriver, tighten the fastening screws to lock the tap in place. Ensure equal pressure on screws to keep the tap aligned.
- e. Verify that the tap is stable and correctly aligned before proceeding to system connections.

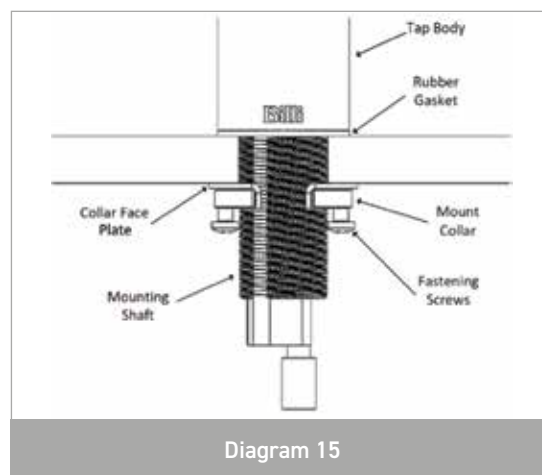
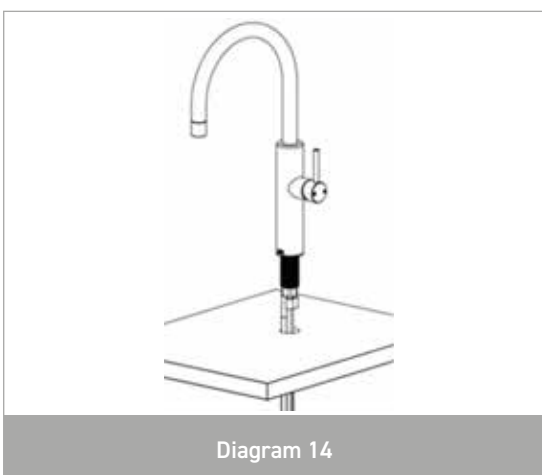
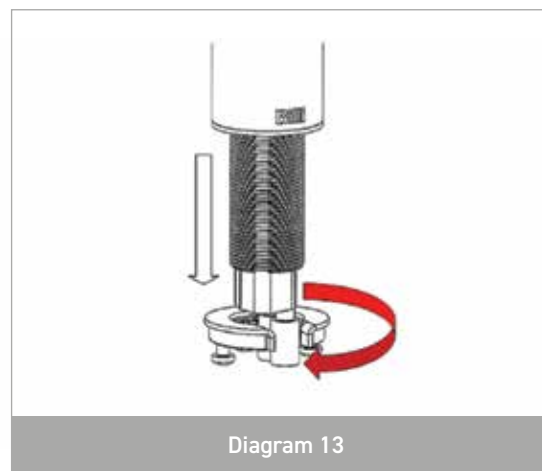
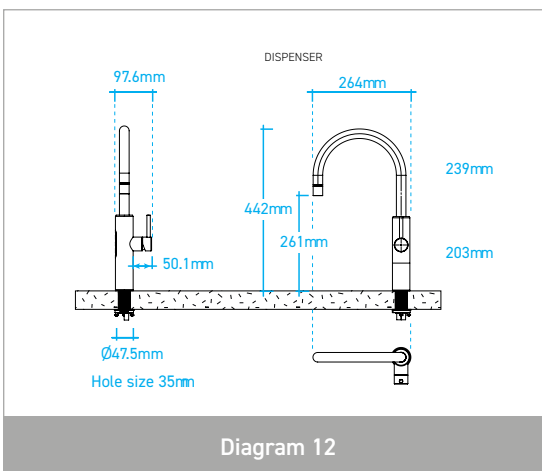
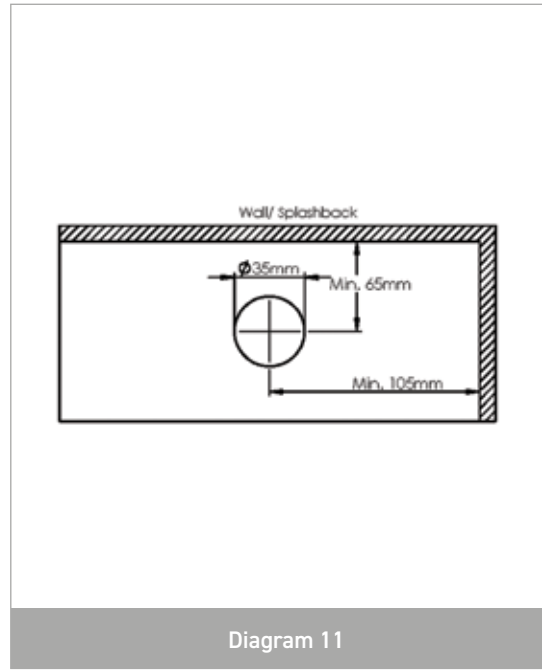
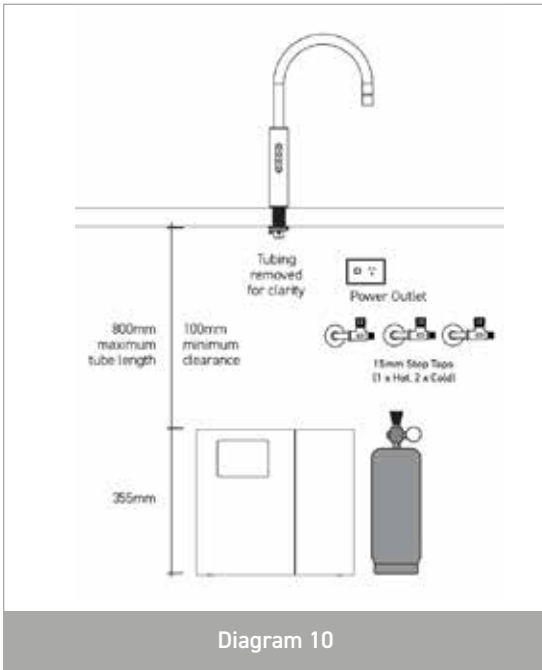

Installing Underbench Module

1. Flush Water Supply

Flush water supply before installation by connecting supplied 600mm flexible braided hose to the supply tap and running water into a bucket. Blockages/unit malfunctions caused by debris are not covered by warranty.

2. Install Underbench Module

Fit your Billi OmniOne in intended install location. Remove all protective films and packaging materials once installed. Refer to diagram 10 for clearance requirements.

3. Connect Water Supply

Connect directly to cold water supply tap using the supplied 600mm flexible braided hose. Ensure there are no kinks or twists in the hose.

DO NOT TURN ON WATER SUPPLY.

4. Connect Dispenser Tubing and Power Cord

Connect dispenser power cord and tubing as shown in Diagram 16 and 17. For Billi OmniOne Plus Models refer to instructions on page 13 for Plus mixer tap installation.

- a. Trim back dispenser tubes to avoid kinking and sagging from excessive length.
 - i. It is advised to leave 100mm of tubing in addition to minimum required length.
 - ii. Only trim PE tubes with a plastic tube cutter. Silicone tubes may be trimmed with a sharp knife or plastic tube cutter.
 - iii. Ensure all tubes are cut square and straight.
- b. Ensure all tubes are fully inserted and silicone tubes are secured with supplied spring clamps in drain connection kit.
- c. Ensure flat face of dispenser power cord is facing forwards when inserted.
- d. For MMT, connect the hot and cold flexi hoses to corresponding hot and cold water supply.

IMPORTANT: Silicone boiling outlet tube (red) and silicone vent tube (grey) MUST NOT be kinked and must be installed with a continual fall and no sag.

5. Connect to Drainage Point

a. Option 1: to dishwasher nipple on waste trap

- i. Drill hole in dishwasher nipple (min. 10mm)
- ii. Push larger end of supplied drain boot fully over dishwasher nipple.
- iii. Push 3/8" tube on supplied drain tube assembly at least 15mm into drain boot. Ensure arrow on drain label is pointing into the drain boot.
- iv. Connect 3/16" tube on supplied drain tube assembly to condenser outlet as per Diagram 18. Nut to be finger tightened only.

b. Option 2: directly to waste trap

- i. Drill a 1/2" hole in the side of the waste trap. Hole is to be least 10mm above water level in the trap and on the sink side only.
- ii. Clip drain adaptor to drain clamp, ensuring tabs on drain adaptor engage with slots in drain clamp.
- iii. Fit drain clamp and adaptor assembly over hole in waste trap. Ensure drain adaptor is oriented with push-fit connection angled up and spigot pushed into drilled hole.
- iv. Tighten drain clamp.
- v. Push 3/8" tube on supplied drain tube assembly fully into drain adaptor. Ensure arrow on drain label is pointing into drain adaptor.
- vi. Connect 3/16" tube on supplied drain tube assembly to condenser outlet as per Diagram 18. Nut to be finger tightened only

6. Connect to CO₂ Cylinder and Regulator

For Billi provided CO₂ cylinders and regulators follow the below instructions. Otherwise refer to separate attached instructions.

- a. Remove plastic cap from threaded outlet of CO₂ cylinder.
- b. Check black pressure control knob on CO₂ regulator is turned fully anti-clockwise (direction of "-" arrow).
- c. Screw CO₂ regulator onto CO₂ cylinder and tighten.
 - i. A small amount of CO₂ will escape while tightening until fully sealed.
 - ii. Avoid breathing air containing high levels of CO₂ or contact with cold escaping gas as per the Material Safety Data Sheet included with the CO₂ cylinder.
- d. Connect to CO₂ regulator to underbench module using supplied black Ø6mm PE tube. Refer to Diagram 16 and 17.
 - i. CO₂ cylinder is to be positioned vertically in cabinet.
 - ii. Trim black Ø6mm PE tube if required and ensure tube is fully inserted.

7. Connect Main Power Cable

Connect supplied power cable to IEC socket at rear of underbench module and to mains power. DO NOT TURN POWER ON.

8. Connect Anti-Scale Filter (Optional)

An external anti-scale filter may be fitted in areas where there is high mineral content in the water supply to help prolong service life and reliability.

The Billi OmniOne supports Ø1/4" PE tube connections to external anti-scale filters. To install:

- a. Disconnect both push-fit elbows connected to the scale filter ports on underbench module by pushing demount rings down and pulling fittings up.
 - i. Bridging tube between the two elbows may also be removed and elbows re-inserted for improved connection angle to anti-scale filter if desired.
- b. Connect anti-scale filter to ports on underbench module, trimming back tubes if required. Refer to Diagram 16 and 17. Ensure tubes are trimmed square and straight, and are fully pushed in.

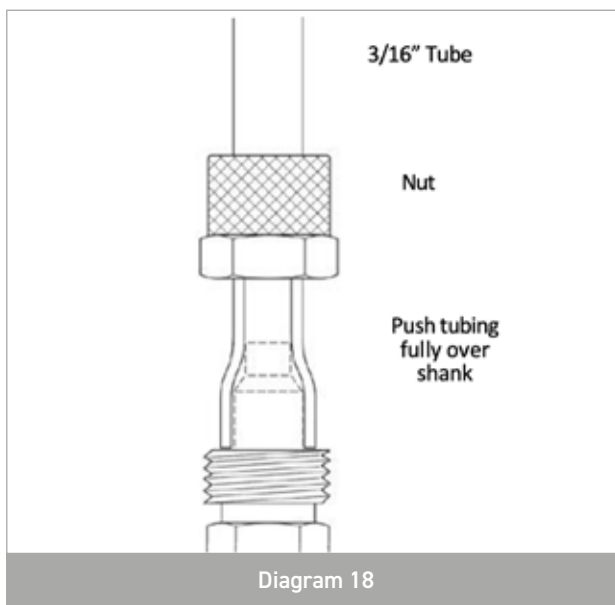
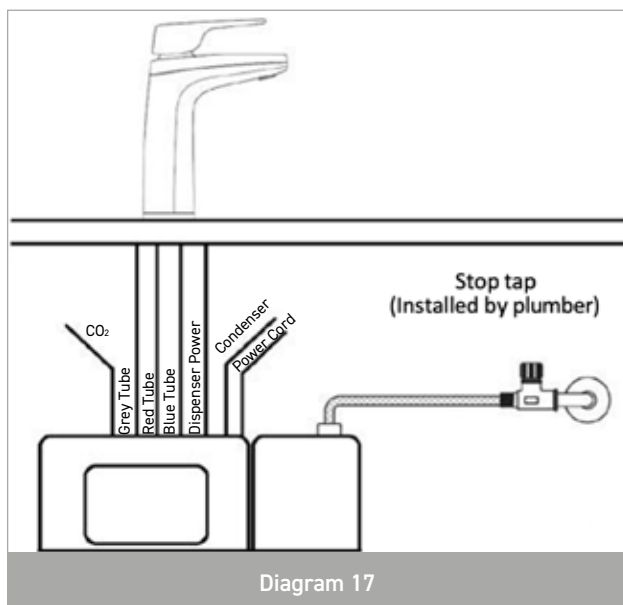
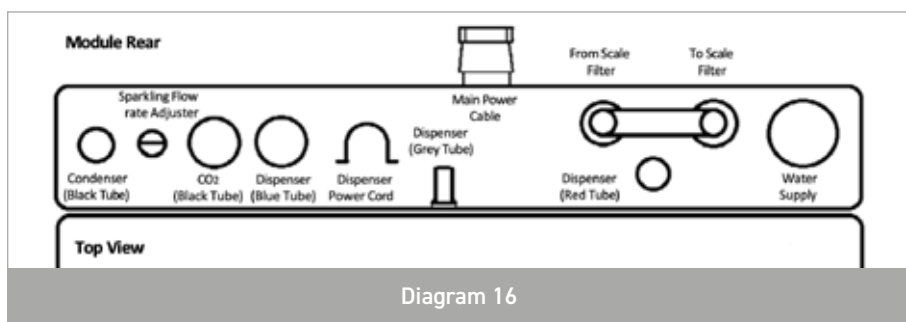

Installing the Plus Mixer Tap (Billi OmniOne Plus Models Only)

Components in Plus Mixer Tap Kit

Before commencing installation, identify the following components:

1. Plus tap assembly with the following fitted:
 - i. Main tap body with mount thread (brass)
 - ii. Finished tap base ring
 - iii. Large o-ring (inset in tap base ring)
 - iv. Mount clamp gasket
 - v. Mount clamp plate
 - vi. Mount clamp (brass)
 - vii. Locking screws x3 (in mount clamp)
2. Tube kit containing:
 - i. Barb adaptor fitting (extended) labelled with "TAP-H" (pre-fitted to tap assembly on some models)
 - ii. 1 metre PVC tubing
3. Accessories kit containing:
 - i. Spring clamps x2
 - ii. Hex key
 - iii. Barb adaptor fitting (short)
 - iv. Aerator key
 - v. 1/2" BSP inline strainer
 - vi. 1/2" BSP male coupling
4. Braided flexible hoses x3:
 - i. Marked "UNIT HOT-IN"
 - ii. Marked "TAP-IN"
 - iii. Marked "TAP-OUT"

Mounting Procedure:

1. Drill or punch mount hole and deburr.
 - Hole size: 35mm
 - Sinktop or benchtop thickness: 1 - 45mm
2. Remove mount clamp gasket and mount clamp plate from mount thread by unscrewing mount clamp.
3. Screw tap base ring up to base of tap, checking large o-ring is inset in tap base ring.
4. Screw barb adaptor fitting (extended) labelled "TAP-H" into marked "H" threaded hole in base of tap and tighten.
5. Insert tap through mount hole and correctly orient tap with Billi Logo facing forwards.
6. Insert mount clamp gasket followed by mount clamp plate over mount thread from underside of benchtop.
7. Thread on mount clamp. NOTE: Ensure slot in mount clamp aligns with tabs in mount clamp plate. Refer to Diagram 19.
8. Firmly hand tighten mount clamp, then use a Philips head screwdriver to tighten all 3 locking screws fitted in the mount clamp.
9. Screw braided flexible hose marked "TAP-OUT" into marked "OUT" threaded hole in base of tap and tighten.
10. Screw braided flexible hose marked "TAP-IN" into marked "IN" threaded hole in base of tap and tighten.
11. Fully push PVC tube onto barb on the barb adaptor fitting (extended) and secure with supplied spring clamp. Note clamp orientation as per Diagram 20.

Connecting Mixer Tap to Billi OmniOne Plus

Fit tubing connections as per Diagram 21 & 22.

1. Separate 1/2" BSP inline strainer from 1/2" BSP male coupling.
2. Connect braided flexible hose marked "TAP-IN" to water supply inlet with 1/2" BSP inline strainer in between.
Use of 1/2" BSP inline strainer is critical.
3. Screw barb adaptor fitting (short) to port on Billi OmniOne marked "Hot Outlet".
4. Trim PVC tubing with a sharp knife to avoid kinking and sagging from excessive length.
 - i. It is advised to leave 100mm of tubing in addition to minimum required length.
5. Fit PVC tubing to barb adaptor fitting (short) and secure with supplied spring clamp.
 - i. Support may be needed for PVC tube if there is a horizontal run.
6. 6. Fit braided flexible hose marked "UNIT HOT-IN" to port on Billi OmniOne marked "Hot Inlet". Join to braided flexible hose marked "TAP-OUT" using 1/2" BSP male coupling.

Operating the Mixer Tap

Operation of mixer tap is as with any single lever mixer tap. Lift lever to start water flow. Swing lever to adjust water temperature as indicated on lever.

Hot water will not be available until the Billi OmniOne boiling water tank has filled and is heated to temperature. Bubbling in the hot water flow indicates insufficient boiling water is available. Wait a few minutes in this instance for tank to fill and heat.

Installing Underbench Module

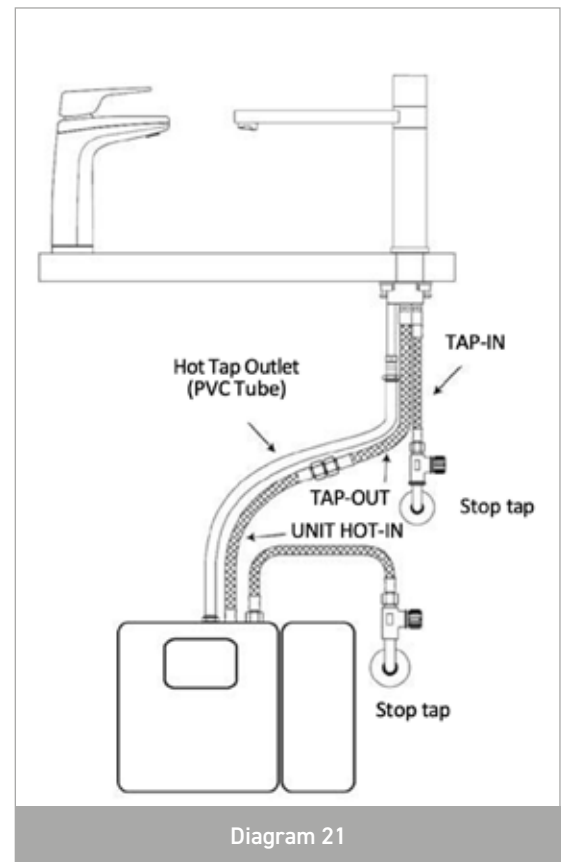
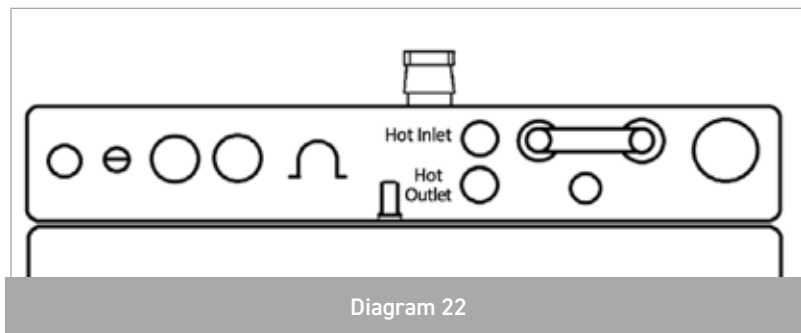
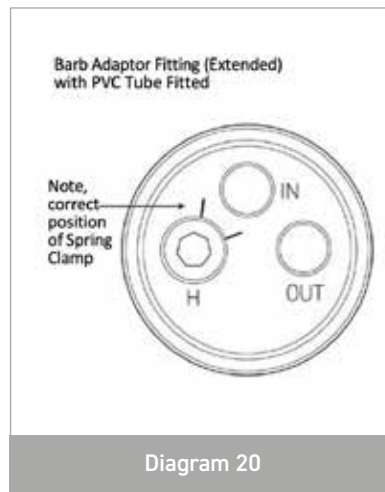
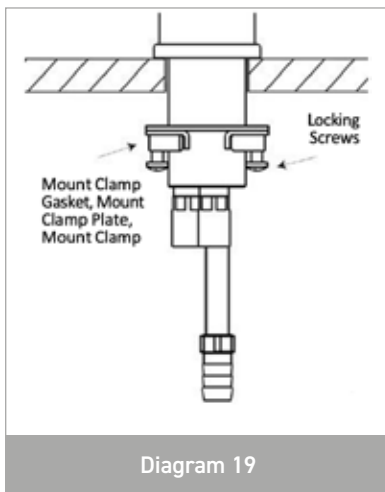

Commissioning

1. Check Filter Cartridge

Open front filter door by pulling in the indicated area and remove foam packing from under pre-installed filter cartridge. Ensure filter cartridge is fully pushed in and securely locked in place. Close front filter door.

2. Turn on Water Supply

Turn on water supply tap and check there are no leaks.

3. Turn on CO₂

For Billi provided CO₂ regulators, open by turning black knob clockwise (direction of "+" arrow). Set pressure to around 3 bar. Tube and connections may settle when the pressure is turned on. Check CO₂ cylinder and connections for leaks using soapy water to test for bubbles.

4. Turn on Mains Power

Check display turns on

5. Automatic Commissioning Sequence

The display will first request for boiling point calibration confirmation, press "Confirm" when this is displayed.

5a. For Multifunction Mixer Tap Only (For XL, skip straight to step 5b).

For XT Motion, skip to 5a (2).

1. Temporarily swap the red and grey silicon tap tubes so that the red boiling tube is connected to the vent outlet of the unit and the grey vent tube is connected to the boiling outlet of the unit. This allows for increased venting during calibration.

2. From main screen, select SETTINGS.

3. Select UNIT SETUP.

4. Next to "Tap Type" scroll right unit AL is displayed.

5. Press SET.

5b. The Billi OmniOne will now carry out the automatic commissioning sequence. This involves various flush and fill sequences, along with automatic calibration of boiling water temperature. Cold water will dispense from the dispenser, along with CO₂ gas. These are all normal parts of the process, and nothing needs to be done in response.

WARNING: Steam and small amounts of hot water may also be discharged from the dispenser during this period.

Commissioning status is displayed on the status bar of the main screen. When commissioning is complete the status bar of the Main Screen will display "System Ready", after which the remaining parameters can be set.

5c. For Multifunction Mixer Tap swap the red and grey silicon tap tubes back so that the red boiling tube is connected to the boiling outlet of the unit and the grey vent tube is connected to the vent outlet of the unit. This is a critical step.

6. Setup CO₂ System

For optimum performance, sparkling dispense flow rate should be set to roughly 2L/min using the sparkling flow rate adjuster on the rear of the underbench module (refer to Diagram 16).

This can be done by continuously dispensing sparkling water into a 500ml vessel until it automatically stops. If it overflows the vessel, the adjuster needs to be turned clockwise. If it doesn't fill the entire vessel, the adjuster needs to be turned anti-clockwise. Continue this process until the vessel fills entirely with one continuous dispense.

It is advised to wait for cold water temperature to stabilise before further adjusting CO₂ pressure. A pressure of between 3 and 4 bar will typically provide the right level of carbonation.

It is normal for a small amount of carbonated water to vent from the dispenser after each dispense of sparkling water.

WARNING: Do not set the CO₂ pressure above **4 bar**.

7. Final Setup

Access the Unit Setup Screen from the Home Screen. From here the boiling water flow rate and the tube length between dispenser and underbench module can be set to optimise performance of the appliance.

Refer to the included User Guide for all other appliance details. Re-check all connections for leaks and ensure all water streams flow correctly. Commissioning is now complete.

Manual Boiling Water Temperature Calibration

In the instance the appliance is relocated to a location where local altitude has changed significantly, it is recommended to manually re-calibrate the boiling water temperature as water boils at lower temperatures at elevated altitudes. This can be done by pressing either temperature on the Home Screen, then selecting and confirming the "Calibrate" button.

Installation and Commission Checklist

- Filter packing foam removed from under filter cartridge.
- All other packaging films and labels removed.
- Dispenser mounted securely. Retaining screw on rear back of dispenser re-fitted for XL/XT Motion dispensers.
- Dispenser swivels 45° in each direction if activated (locking piece removed). (XL Tap Only)
- Tubing is cut to correct lengths and not kinked, twisted, or sagging. Red and grey silicone tubes have continuous fall.
- Tubing secured correctly. Silicone tubes secured with spring clamps, PE tubes fully inserted, and nuts correctly tightened.
- Water main flushed before connection to appliance.
- Appliance connected to COLD mains water supply.
- Sufficient clearance around unit and dispenser as recommended.
- Power circuit fitted with an RCD (earth leakage protection device).
- Sawdust and any other debris cleaned out of cupboard area.
- Initial program settings correctly set for dispenser tube length.
- Time and date correctly set.
- Appliance heating and cooling correctly after automatic commissioning sequence. Red and blue dispenser icons flashing (or on continually when correct temperature reached).
- CO₂ pressure correctly set with no leaks.
- Sparkling water flow rate correctly set.
- Boiling and chilled water flow steady.



Please scan the QR code for all support information.

Billi Australia Pty Ltd

P 1800 812 321
W www.billi.com.au

Billi New Zealand Ltd

P 0800 636 0 636
W www.billi.co.nz

Billi®

Designed and manufactured in Australia.

Billi® is a registered trademark of Billi Australia Pty Ltd. Billi OmniOne™ is trademark of Billi Australia Pty Ltd. All rights reserved. © Copyright protected. Billi Australia Pty Ltd has a policy of continual improvement, all details are subject to change without notice. All goods are sold subject to our published terms and conditions.

Billi[®]