

#### Billi Alpine Sparkling 100 with Dual Slimline dispenser

The Alpine Sparkling system offers an advanced ice bank chilling solution to optimise the user experience of instant chilled and sparkling filtered water. This system features a highly efficient CO2 injection system, ensuring high saturation of CO2 for longer-lasting and tastier sparkling water.

Users can personalise their experience with adjustable controls for the level of carbonation (up to 5 bar of CO2 pressure), making it a perfect choice for those seeking ultimate refreshment.



CHILLED



SPARKLING



#### Features



FRESHER  
SPARKLING  
TASTE



ICE BANK  
TECHNOLOGY



ADJUSTABLE  
CHILLED  
TEMPERATURE



ADJUSTABLE  
SPARKLING  
LEVEL



SPACE SAVING  
DESIGN



HACCP  
CERTIFIED

Dual Slimline Dispenser

Alpine Sparkling Under-Bench Unit



#### Finishes

##### Standard Finishes



CH -  
Chrome



BR -  
Brushed



MB -  
Matte Black

Add the relevant Finish Code to the Product code to complete your specification, eg. 933100DCH-LF

#### Accessories

**992810** - Slimline font



**990727** - Tubing extension kit for slimline sparkling 2 metres

#### Product Specifications

Water Type	CS
Dispenser	D - Dual Lever Slimline Dispenser
Mixer Tapware	N/A
Product Code	933100D
Warranty	3 years manufacturers warranty
Under-Bench Dimensions	255mm(W) x 410mm (H) x 420mm (D)
Boiling Output	N/A
Chilled* Output	Up to 100 cups per hour
Sparkling* Output	Up to 100 cups per hour
50°C Hot Water Output	N/A
Min / Max Dispenser Temp	6°C / 12°C
Power Plug	10 amp
Power Rating	370W, 220-240V, 50-60Hz
Water Pressure	Min. 250kPa
Ecolabel	N/A
EPD	N/A
Greenstar Contribution	N/A
Watermark License	WM-022690
Lead Free	✓
Section J7.7 (NCC)	N/A
WELS	N/A
WELL	Cornerstone Membership
Management Systems	Every Billi drinking water appliance is manufactured under the strictest standards and is certified in accordance with: ISO9001 for QMS (FS 790754), ISO14001 for EMS (EMS 801468) and ISO45001 for OSHS (OHS 801469).
Food Handling	HACCP license no. PE-138-BIL-R1-02
Filtration	994051 - 5.0 Micron supplied standard

\*Combined usage for Chilled and Sparkling.

Scan the QR code access  
our Revit families on  
**bimstore**

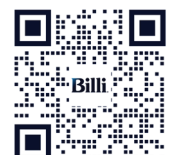

## Technical Drawings

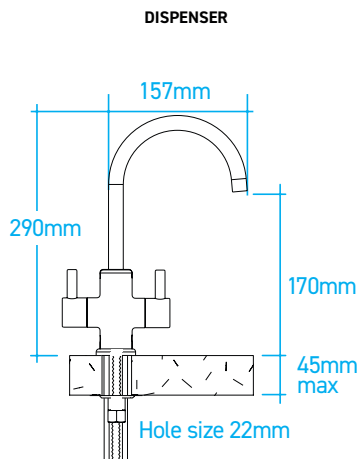

## UNDER-BENCH UNITS



\*Drawings are for guidance during Specification, refer to Installation requirements for final install. All efforts are made to ensure Compliance & Certifications claims are current, however this is subject to change without notice. Billi assumes no liability or responsibility for out of date information.

## Installation Requirements

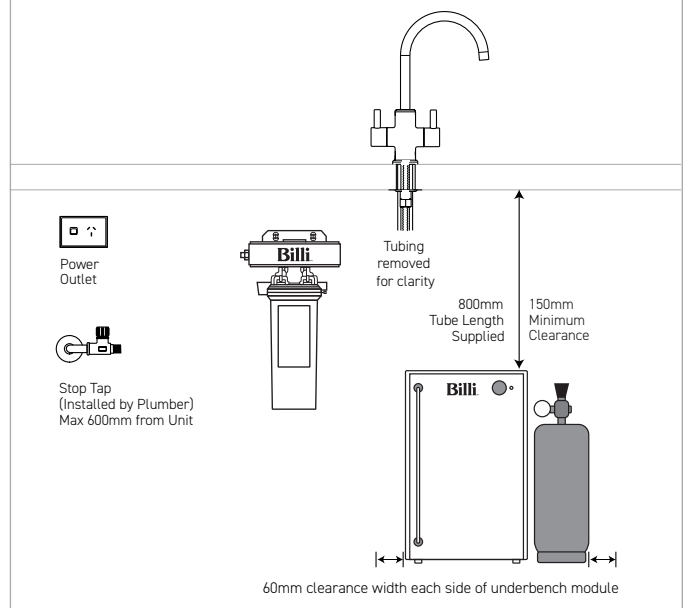

## Installation Notes

- Electrical** A standard 10 amp power outlet is required, located no further than 1000mm from the underbench unit. The system is supplied with a 1 metre flex cord and plug.
- Water** A single 1/2" BSP (15mm) stop-tap with a male thread should be installed in an easily accessible position. Water supply must be microbiologically safe to drink, with a minimum dynamic water pressure of 250kPa and a maximum of 1000kPa.
- Pressure Valve** Integrated 500kPa pressure limiting and dual check valve is pre-installed to the unit inlet.
- CO2 MSDS** The CO<sub>2</sub> gas cylinder supplied must be secured in a suitable location. Each cylinder contains 1100g of CO<sub>2</sub> and should be installed in a well ventilated area. Each cylinder will provide between 200-350L of sparkling water depending on the unit settings. The MSDS is available on [www.billi.com.au](http://www.billi.com.au) for a complete list of specifications and warnings. Replacement gas cylinders are available from Billi. CO<sub>2</sub> Cylinder - single 996911 or double 996912.
- Stone Benches** Billi has a no-cut policy regarding all stone benches in compliance with regulations. The safety of our team and customers remains Billi's top priority.
- Ventilation** This is an air cooled product, ventilation is vital under normal operating conditions. Failure to follow manufacturers ventilation recommendations can risk warranty.

## Filtration - Most Recommended Replacement Filters

Billi range of premium filters utilize BWT's unique FibronX® technology, providing superior taste, water quality, filter life longevity and peace of mind when it comes to hygiene.

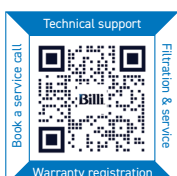

Please scan the QR code for all support information.

**Billi Australia Pty Ltd**  
P 1800 812 321  
W [www.billi.com.au](http://www.billi.com.au)

**Billi New Zealand Ltd**  
P 0800 636 0 636  
W [www.billi.co.nz](http://www.billi.co.nz)

**Billi**