



Billi Quadra 4180 with XL Levered Dispenser

The Quadra Boiling and Chilled range is a commercial drinking water solution that is water cooled, so requires no joinery venting. The drawcard for the entire Quadra range is the use of innovative energy reclaim technology which enables space savings, energy efficiency and completely eliminates exhaust heat transfer. All Quadra boiling and chilled products are Global Greentag certified to a Gold standard.

The XL Levered dispenser is streamlined and elegant, offering boiling and chilled output delivered safely and at your own pace simply by operating the position-sensitive levers.



BOILING



CHILLED



Features



AUSTRALIAN
DESIGNED
& MADE



WATER
COOLED
TECHNOLOGY



HEAT
EXCHANGE
TECHNOLOGY



VENT-FREE
INSTALLATION



ENERGY
EFFICIENT



ECOLABEL
CERTIFIED

XL Levered
Dispenser



Quadra 4180
Under-Bench Unit



Finishes

Standard Finishes



CH -
Chrome



BR -
Brushed



MB -
Matte Black



MW -
Matte White

Special Order Finishes



UB -
Urban Brass



GM -
Gun Metal Grey



SB -
Sable Bronze

Add the relevant Finish Code to the Product code to complete your specification eg 904180LCH-LF

Accessories

992800 - 70mm Riser & Font



992820 - 70mm Riser



992803 - 120mm Riser & Font



992830 - 120mm Riser



990720 - Tubing Extension Kit for X series dual temp dispensers 2mtrs

Product Specifications

Water Type	BC
Dispenser	L - XL Levered Dispenser
Mixer Tapware	N/A
Product Code	904180L
Warranty	3 years manufacturers warranty
Under-Bench Dimensions	315mm(W) x 340mm (H) x 465mm (D)
Boiling Output	Up to 250 cups per hour
Chilled Output	Up to 175 cups per hour
Sparkling Output	N/A
50°C Hot Water Output	N/A
Min / Max Dispenser Temp	6°C / 99°C
Power Plug	20 amp
Power Rating	4300W, 220-240V ~ 50-60Hz
Water Pressure	Min. 250kPa
Ecolabel	Global GreenTag LCARate GOLD
EPD	✓
Greenstar Contribution	Up to 16 Points
Watermark License	WM-021525
Lead Free	✓
Section J7.7 (NCC)	✓
WELS	N/A
WELL	Cornerstone Membership
Management Systems	Every Billi drinking water appliance is manufactured under the strictest standards and is certified in accordance with: ISO9001 for QMS (FS 790754), ISO14001 for EMS (EMS 801468) and ISO45001 for OSHS (OHS 801469).
Food Handling	HACCP License No. PE-138-BIL-R1-03
Filtration	994051 - 5.0 Micron supplied standard

Scan the QR code access
our Revit families on

bimstore

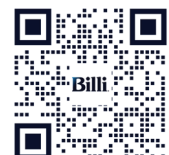

Technical Drawings

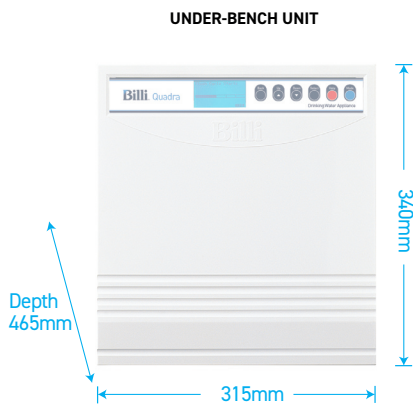
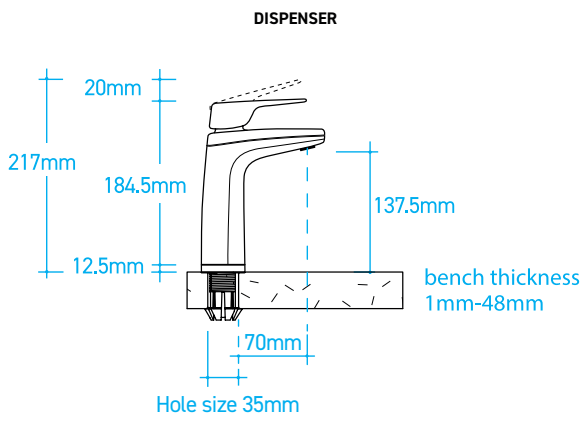

* Drawings are for guidance during Specification, refer to Installation requirements for final install. All efforts are made to ensure Compliance & Certifications claims are current, however this is subject to change without notice. Billi assumes no liability or responsibility for out of date information.

Installation Requirements

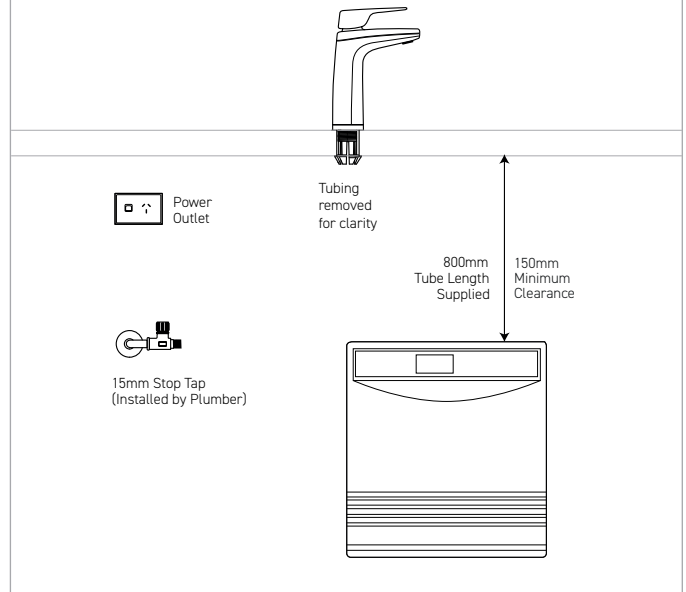

Installation Notes

- Electrical** A standard 20 amp power outlet is required, located no further than 1000mm from the underbench unit. The system is supplied with a 1 metre flex cord and plug.
- Water** A single 1/2" BSP (15mm) stop-tap with a male thread should be installed in an easily accessible position. Water supply must be microbiologically safe to drink, with a minimum dynamic water pressure of 250kPa and a maximum of 1000kPa.
- Pressure Valve** Integrated 500kPa pressure limiting and dual check valve is pre-installed to the unit inlet.
- Stone Benches** Billi has a no-cut policy regarding all stone benches in compliance with regulations. The safety of our team and customers remains Billi's top priority.
- Ventilation** No joinery ventilation or accessories are required for this Billi product (water cooled technology).

Filtration - Most Recommended Replacement Filters

Billi range of premium filters utilize BWT's unique FibronX® technology, providing superior taste, water quality, filter life longevity and peace of mind when it comes to hygiene.

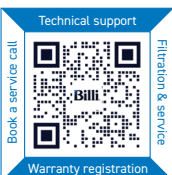

Please scan the QR code for all support information.

Billi Australia Pty Ltd
P 1800 812 321
W www.billi.com.au

Billi New Zealand Ltd
P 0800 636 0 636
W www.billi.co.nz

