

Billi®

Commercial Installation Guide

Billi Eco Sparkling (906000)

Tap Options:

XL, XT Motion,
Multifunction Mixer Tap



CONTENTS

Warnings and Important Information	3
Unpacking your Billi Eco Sparking Unit	4
Included Components	4
Installation Requirements	4
Installation Requirements cont.	5
Installing XL Dispenser	6
Installing XL & XT Motion Dispenser	7
Installing the dispenser. contd.	8
Installing Multifunction Mixer Tapware	9
Installing Underbench Module	10
Installing Underbench Module	11
Commissioning the Eco Sparkling	12
Installation and Commission Checklist	15

Warnings and Important Information

- For continued safety of this appliance, it must be installed, operated and maintained in accordance with the manufacturer's instructions. Your appliance should be installed by the manufacturer, a service agent, or any other suitably qualified tradesperson.
- For correct operation of this appliance, it is essential to observe the instructions as outlined in this booklet.
- Do not use this appliance with water that is microbiologically unsafe or with water of unknown quality without adequate disinfection before or after the system. Systems certified for cyst reduction may be used on disinfected water that may contain filterable cysts.
- Filter replacement must be performed at intervals of not more than 12 months.
- Use this appliance only as directed in these instructions and only for its designed purpose.
- This appliance is not intended for use by persons (including children) with reduced physical, sensory or mental capabilities, or persons with lack of experience and knowledge, unless they are supervised or have been given instruction concerning use by a person responsible for their safety.
- This appliance is not to be installed in an area where a water jet could be used. Children should be supervised to ensure that they do not play with the appliance.
- **DANGER:** The operation of the flange mounted thermal cut-out indicates a possibly dangerous situation. Do not reset the thermal cut-out until the appliance has been serviced by a suitably qualified person.
- **WARNING:** Do not connect any restrictor, pressure relief device or non-return valve to the vent pipe of this appliance.
- **WARNING:** When positioning the appliance ensure the power supply cord is not trapped or damaged.
- **WARNING:** Do not install the appliance using a power board, double power adaptor or any other similar device. The appliance is to be plugged directly into a suitably protected and rated power point.
- **WARNING:** If the power supply cord is damaged, it must be replaced by the manufacturer, its service agent, or similarly qualified persons. The appliance is not to be used until the power supply cord is repaired.
- **WARNING:** Avoid spillages of any kind on all electrical connectors.
- **WARNING:** Potential injury can result from misuse.
- **WARNING:** Internal surfaces adjacent to and directly in contact with the heating element are subject to residual heat after use.
- **WARNING:** Only Billi hose and tube kits as supplied with the appliance are to be used. Old or other manufacturer's hose and tube kits should not be used.
- **WARNING:** This appliance may deliver water at high temperature. Refer to the plumbing code of Australia (PCA), local requirements and installation instructions to determine if additional temperature control is required.
- **WARNING:** Installation shall conform to the plumbing code of Australia (PCA) or relevant local requirements.
- If the appliance is installed in a location where the ambient air temperature could fall below 4°C, do not turn off power to the appliance to prevent malfunction. This safeguard does not offer protection to connecting pipework and fittings external to the appliance.
- The appliance is designed to operate in an ambient air temperature range of 5°C to 30°C.
- Turn off power to the appliance by unplugging the power cord from the connected power point. Only do so after the inlet water supply has been turned off.
- The appliance is intended to be used in commercial and similar applications such as:
 - Staff kitchen areas in shops, offices, and other working environments.
 - By clients in hotels, motels, and other residential type environments.
 - Bed and breakfast type environments.
 - Catering and similar non-retail applications.
- **Please note maximum inlet water pressure is 1000kPa.**

Unpacking your Billi Eco Sparking Unit

Before commencing installation, carefully check for any damage to outer carton, inner liner, appliance metalwork, pipework fittings and electrical power cord. If damage is found, please photograph and record details for use if a claim is to be made.

WARNINGS relating to this appliance must be read before commencing installation. Refer to page 3.

Included Components

Before commencing installation, identify the following components:

- | | |
|----------------------------------------------------|---------------------------------------------|
| 1. Boiling water module | 12. 600mm flexible braided hose |
| 2. Chilled water module | 13. Filter cartridge (installed) |
| 3. Dispenser Kit (Depending on region) | 14. User guide |
| 4. Power Cord for Chiller Module | 15. Warranty card |
| 5. CO ₂ cylinder (Depending on region) | 16. Caution label |
| 6. CO ₂ regulator (Depending on region) | 17. Plastic Ø6mm tube cap |
| 7. Dispenser | 18. 5mm spacer pads |
| 8. Tube spring clamps x 2 | 19. Ventilation grille - cupboard base |
| 9. 1 x clear and 2 x black Ø6 mm PE tubes | 20. 4 x Screws |
| 10. 4 x 6mm stem elbows | 21. 1 x Allen Key (2.5mm) |
| 11. 1 x flow adjuster | 22. Installation Guide |
| | 23. Vent Installation Kit |
| | 24. Sparkling Dual Tap Install Instructions |

Installation Requirements

Determine Unit Location

Plan the installation carefully, taking into consideration dispenser tube lengths, position of power and water outlets, ventilation airspace requirements and access for service. The Billi Eco is to be installed indoors only and must be installed on a level surface with the access panel facing to the front of the cupboard. Refer to diagrams 1, 2, 3a, 3b and 4. Diagram 4 shows minimum clearances required around the units for ventilation.

Power Requirements

Eco Sparkling requires 2 single or 1 double 10 amp GPO, installed in an accessible position. Refer to Diagram 1. Power circuits must be fitted with an earth leakage protection device (RCD). Both boiling and chilled water module are supplied with a 1 meter flex cord and plug. Cupboard ventilation fan kits require an extra 10A GPO outlet.

Water Supply

The Billi Eco must only be connected to a cold water supply. A 1/2" BSP stop tap (not supplied) is to be installed in an easily accessible location within 600mm of the Billi Eco water supply inlet. A certified pressure limiting valve with internal dual check valve for backflow prevention is incorporated in the appliance.

IMPORTANT: Do not fit an additional pressure limiting valve or dual check valve.

Inlet water supply requirements:

Dynamic pressure: Min. 250kPa – Max. 1000kPa

Water temperature: Min. 5°C – Max. 30°C

IMPORTANT: Do not install where the incoming water is microbiologically unsafe or with water of unknown quality.

Ventilation

A minimum cupboard depth of 520mm is required for installation. Adequate cross-ventilation is required, minimum of 30mm and 60mm respectively on each side (left & right) is recommended. 150mm of clearance is recommended above the appliance for accessibility and to prevent hoses being kinked.

IMPORTANT: Insufficient ventilation will cause inefficient refrigeration system operation, increasing power usage and potential failure.

Installation Requirements cont.

Determine Unit Location

The Billi Eco boiling module has the following dimensions (refer **Diagram 3a**):

Height	Width	Depth
340mm	180mm	365mm

The Billi Eco chiller module has the following dimensions (refer **Diagram 3b**):

Height	Width	Depth
395mm	255mm	420mm

Ventilation Grilles

A ventilation kit including lower cupboard vent grille and 5mm door spacers is supplied with each Billi Eco Sparkling filtered water system. Separate installation instructions are provided within the vent kit packaging. For lower usage, domestic installations, sufficient ventilation may be provided by natural air movement through the cupboard airspace.

Please refer to 611002 Vent Kit document included with the package.

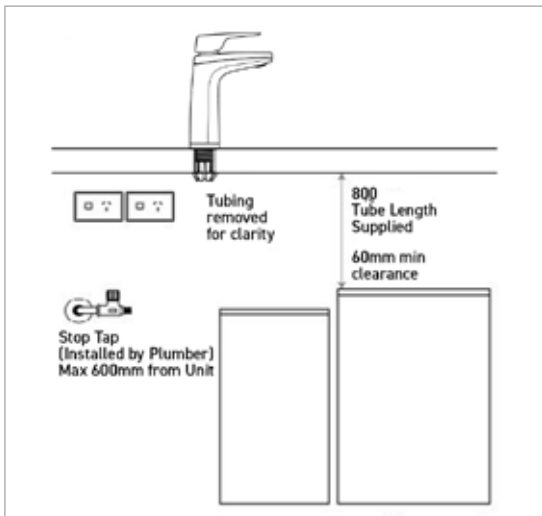

Diagram 1

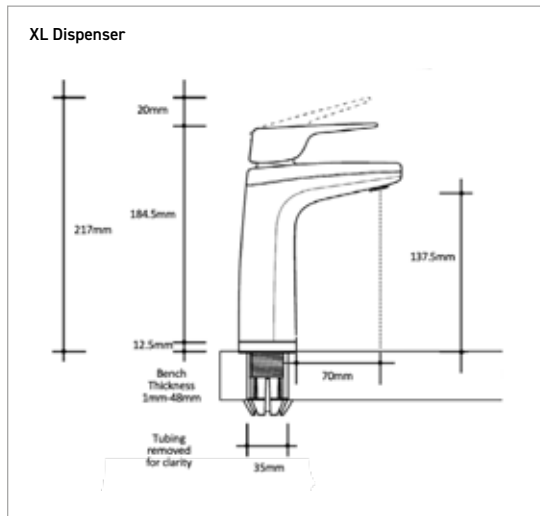

Diagram 2.1

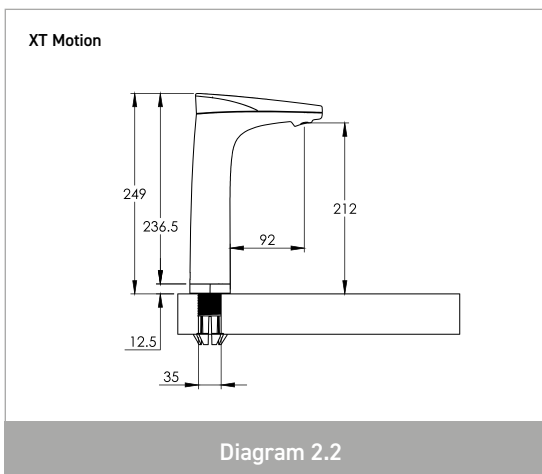

Diagram 2.2

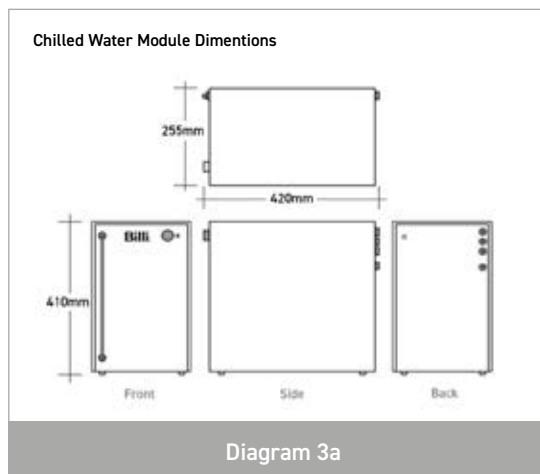

Diagram 3a

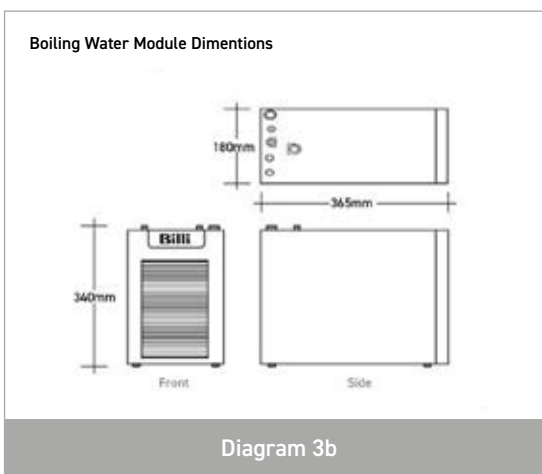

Diagram 3b

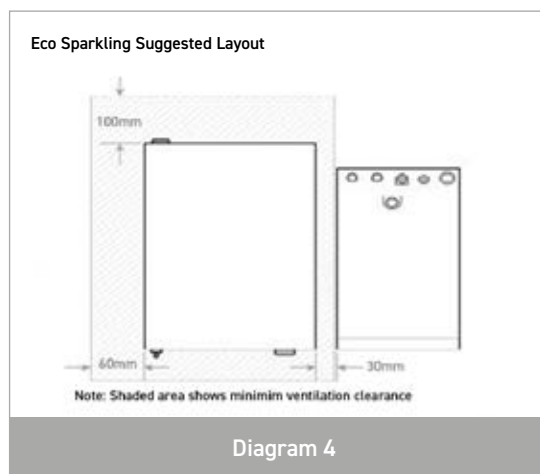

Diagram 4

Installing XL Dispenser

Installing XL & XT Motion Dispenser

IMPORTANT: This Billi appliance is to be installed by a licensed tradesperson in accordance with AS/NZS 3500.1 and AS/NZ 3500.2 and in compliance with applicable state regulatory requirements. For correct operation of this appliance, it is essential to observe the manufacturer's instructions.

IMPORTANT: The Billi XL & XT Motion dispenser is supplied with base assembly preassembled into dispenser upper and this must be first removed prior to starting installation. Using Allen key supplied in installation kit, remove chrome plated M4 screw from rear of housing. Twist base casting around 60° and then slide assembly out of upper housing. Carefully pull tubing and electrical cable and plug through base assembly.

Components in Dispenser Kit

Before commencing installation, identify the following components:

1. Dispenser
2. Large D-Washer

1. Determine Dispenser Location

The X-series dispensers can be installed on a surface 1mm – 48mm thick and requires a hole size of $\varnothing 35$ mm. All tube and signal cable lengths are 800mm and connect to top rear of underbench module.

Refer to **Diagram 5** for a base template that may be cut out to assist in positioning, and **Diagram 2** for dimensions of dispenser. Ensure to leave sufficient room for the safety lock button on rear of dispenser head.

2. Cut $\varnothing 35$ mm Hole in Sinktop or Benchtop

a. Stainless Steel Sinktop

A suitable $\varnothing 35$ mm hole punch (Part no: 857901) is available as an accessory from Billi. If possible, cut hole with die mounted below the sinktop surface so burrs are pulled downwards. Alternatively, remove burrs and radius edge of hole with a fine file.

b. Timber/Laminate Benchtop

Take care to avoid chipping of surface as the drill breaks through underside of the benchtop. We recommend drilling a small pilot hole through the benchtop, partially drilling $\varnothing 35$ mm hole from underneath, and then completing drilling hole from above.

c. Stone bench top

For all stone benchtops we recommend you use a certified stone mason to pre-drill the hole before arriving at site to mitigate the risk of silicosis or airborne particulate matter. Billi is unable to provide on-site drilling services and will always prioritise the safety of our staff & customers.

3. Prepare Dispenser Base Assembly for Installation

- a) Remove retaining screw on rear back of dispenser using supplied hex key.
- b) Turn dispenser base 30° then pull down to separate completely from main body, sliding over tubes and power cord. Refer to **Diagram 4 and 5**.
- c) Place main body aside.
- d) Activate dispenser swivel feature if desired by pushing out locking piece as shown in **Diagram 6**.
- e) Remove base casting from barbed mounting shaft by unscrewing locking nut.
- f) Position critical locking sleeve at base of barbed mounting shaft, ensuring it contacts the moulded stop. Refer to **Diagram 7**.
- g) Push barbed mounting shaft through underside of mount hole with barb facing down. Large D-washer is recommended to be used if there is room.
 - i. Insert D-washer over barbed mounting shaft prior to insertion through bench if it is used. **Refer to Diagram 7**.
- h) Re-assemble base casting and locking nut with barbed mounting shaft. Take care to align flat face on barbed mounting shaft with flat face in hole of base casting.
- i) Finger tighten locking nut.
- j) CHECK CRITICAL LOCKING SLEEVE IS STILL POSITIONED AT BASE OF BARBED MOUNTING SHAFT.**
- k) Ensure barb is centred in mount hole and alignment of base is correct. Moderately tighten locking nut using multigrips or spanner. Avoid overtightening the locking nut to avoid damaging the barbed mounting shaft. Refer to **Diagram 8**.

4. Install Dispenser Main Body

- a) Feed all tubing and power cord through hole in dispenser base. Feed power cord first followed by tubes. **Refer to Diagram 9**.
- b) Gently pull all tubes and power cords, ensuring tubes aren't kinked or twisted. Do not attempt to force tubing or power cord through with a pointed object as this may cause damage.
- c) Re-assemble dispenser base and main body by turning main body 30° in relation to dispenser base and pushing down. Gently pull tubing and power cord downwards at the same time from underneath to prevent kinking and bunching.
- d) Turn dispenser main body straight once fully inserted and re-install retaining screw on rear back of dispenser.
- e) If swivel feature has been activated check dispenser now smoothly swivels 45° in each direction

Installing the dispenser. contd.

Dispenser base XL

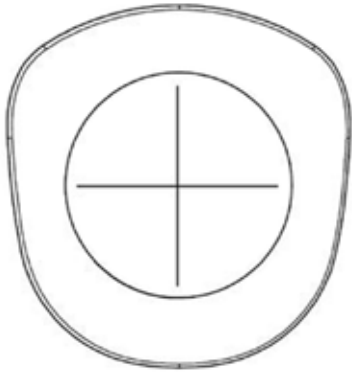

Diagram 5.1

Dispenser base XT Motion

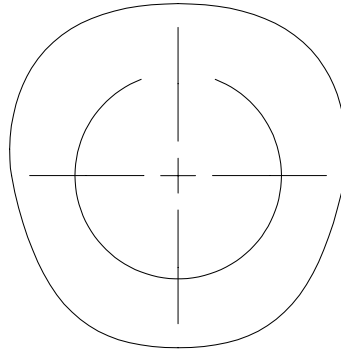

Diagram 5.2

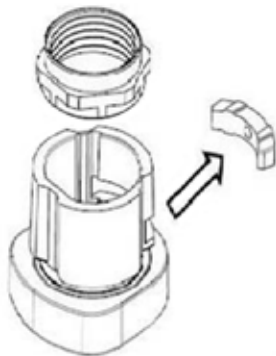

Diagram 6

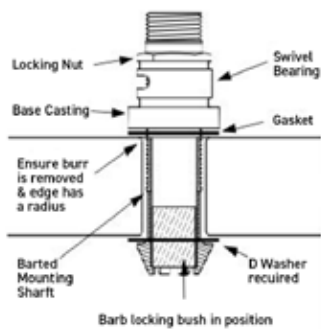

Diagram 7

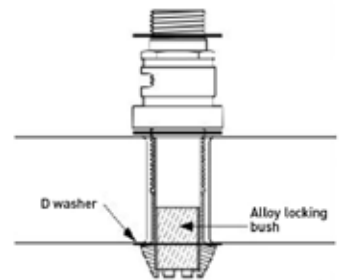

Diagram 8

Dispenser XL

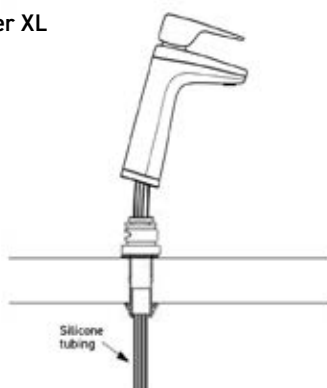

Diagram 9.1

Dispenser XT Motion

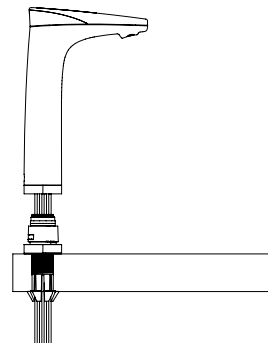
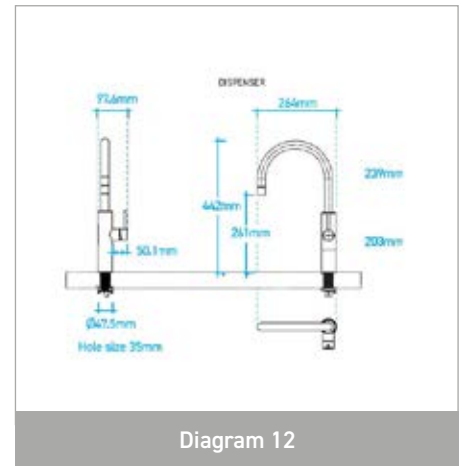
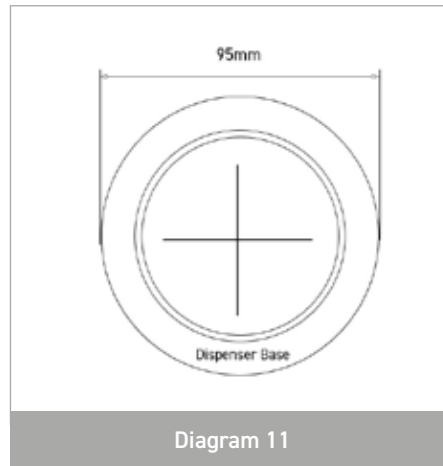
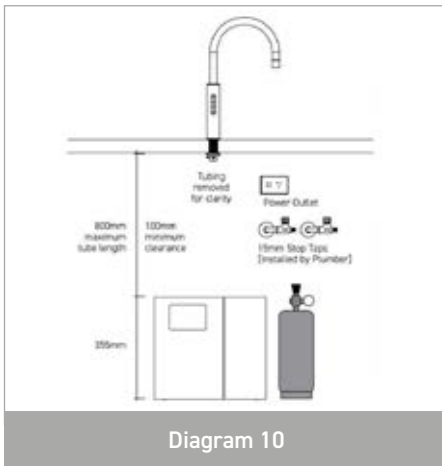

Diagram 9.2

Installing Multifunction Mixer Tapware



1. Determine Dispenser Location

The MMT dispenser can be installed on a surface 1mm –48mm thick and requires a hole size of $\varnothing 35\text{mm}$. All tube and signal cable lengths are 800mm and connect to the top rear of underbench module.

Refer to Diagram 11 for a base template that may be cut out to assist in positioning, and Diagram 12 for dimensions of dispenser. Ensure to leave sufficient room for the safety lock button on rear of dispenser head.

2. Cut $\varnothing 35\text{mm}$ Hole in Sink top or Benchtop

a. Stainless Steel Sink top

A suitable $\varnothing 35\text{mm}$ hole punch (Part no: 857901) is available as an accessory from Billi Australia Pty Ltd. If possible, cut the hole with the die mounted below the sink top surface so burrs are pulled downwards. Alternatively, remove burrs and radius edge of hole with a fine file.

b. Timber/Laminate Benchtop

Take care to avoid a large chip breaking as the drill breaks through the underside surface. We recommend drilling a small pilot hole through the benchtop, partially drilling $\varnothing 35\text{mm}$ hole from underneath, and then completing the drilling hole from above.

*For all stone benchtops we recommend you use a certified stone mason to pre-drill the hole.

3. Prepare MMT Mixer Tap Base for Installation

- Remove the ring bracket located underneath the MMT tap assembly by turning it counterclockwise. Refer to Diagram 13.
- Set the ring bracket aside in a safe location.
- Ensure the tubing is straightened and free from kinks before proceeding.

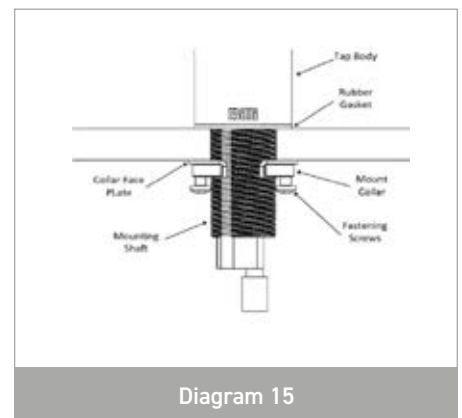
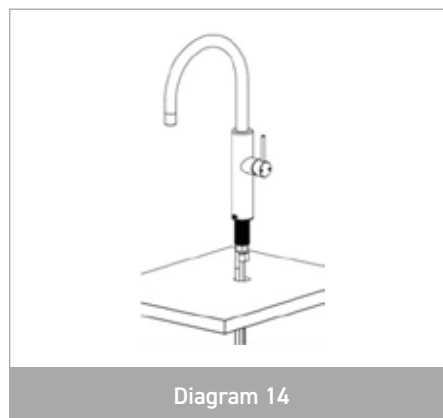
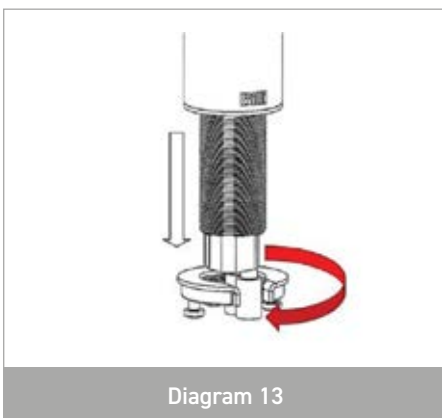

Installing Underbench Module

1. Flush Water Supply

Flush water supply before installation by connecting supplied 600mm flexible braided hose to the supply tap and running water into a bucket.

Blockages/unit malfunctions caused by debris are **not** covered by warranty.

2. Install Underbench Module

Position both underbench modules in intended location, taking care to maintain clearance and ventilation requirements. Refer to Diagram 1 and Diagram 4. Ensure there is adequate clearance for ventilation and service access to the units, considering the tube lengths and space available.

3. Connect Dispenser Tubing and Electrical Plug

IMPORTANT: Boiling outlet (red), vent tube (grey) must not be kinked and must be installed with a continual fall and no sag. Connect all tubing and electrical plug as shown.

INSTALLERS TIP: It is easiest to fit these tubes to chiller before unit is installed. Before inserting tubing into push-fit connectors, ensure that tube ends are cleanly cut and not flattened or kinked. Tube is pushed firmly into connector until properly seated. (To release, press the retaining collet ring inwards while pulling gently on the tube).

Connect all tubing and electrical plug as shown in Diagrams 10 and 11.

- a. Trim silicon tubes to correct lengths using a sharp knife or plastic tube cutter. Avoid leaving excess tubing which will sag and trap water. Fit spring clamps to tubing prior to connecting.
- b. Red silicone tube pushes on to boiling module fitting labelled BOILING (RED). Secure with spring clamp supplied.
- c. Grey silicone tube pushes on to boiling module fitting labelled VENT (GREY) Secure with spring clamp supplied.
- d. Dispenser electrical cable Mini-Din connector plugs into boiling unit socket.
- e. 6mm PE tube connections are made using push-fit connectors. There are 3 x Ø6mm tubes supplied loose in your installation kit; 2 x black, and 1 x natural (clear). Each tube has an elbow fitting attached to one end. An additional 6mm elbow is supplied which is to be fitted to the blue dispenser tube once tube has been trimmed to correct length.
- f. Tube elbows are inserted into fittings at rear of chiller. Refer to diagram 10 and 11 for correct tube orientation and colour coding.
- g. Connect power lead with 6-way mini din plug from boiling module to socket located at rear RHS of the sparkling water module -refer to diagram Rear mounted plug guide bracket helps to locate socket position and orientate plug correctly.

IMPORTANT: At this stage, **do not** connect CLEAR feed tube between boiling and chilled water modules. This will be connected once ice bank had been filled. Instead, connect the BLACK tube to the ambient water fitting on the boiling module. Refer to diagram 10.

4. Sparkling Flow Controller:

- a. Position adjustable flow controller as high in the cupboard and as close to the dispenser as practical while still ensuring it is accessible for adjusting later. Please refer to diagram 10.
- b. Cut tube at required location, and insert flow controller in line as per diagram 10. Ensure direction matches the diagram.

5. Connect CO₂ bottle and pressure regulator

- a. Remove CO₂ bottle from packaging box. Remove plastic cap from threaded outlet of bottle.
- b. Remove CO₂ pressure regulator from packaging and check pressure control knob is turned fully anticlockwise.
- c. Holding the CO₂ bottle upright, screw the pressure regulator onto outlet. A small amount of CO₂ gas will escape until regulator has been tightened.
- d. Decide location of CO₂ bottle in cupboard space.
- e. Black Ø6 mm tube from chiller module connects to outlet of gas regulator. Trim tube to correct length, push into fitting and tighten retaining nut. Refer to diagram 10 & 13.

Installing Underbench Module

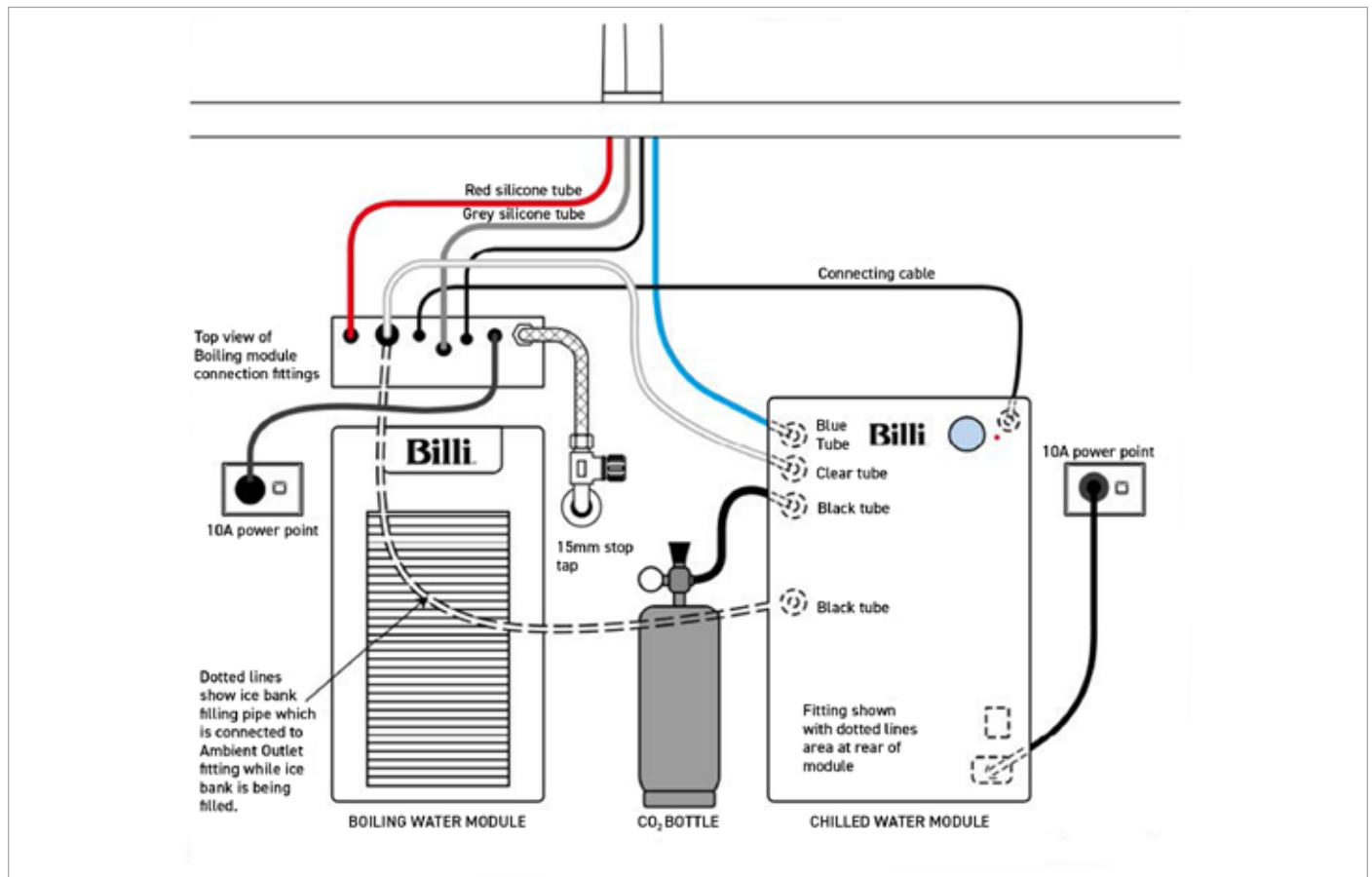
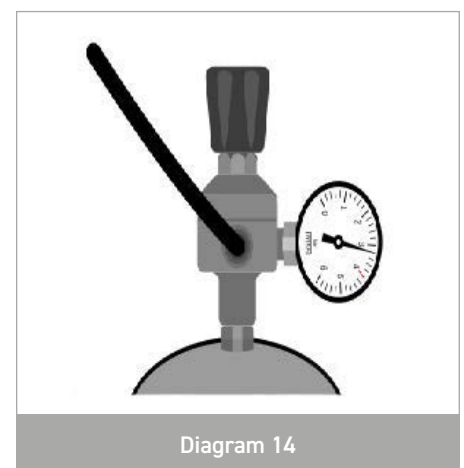
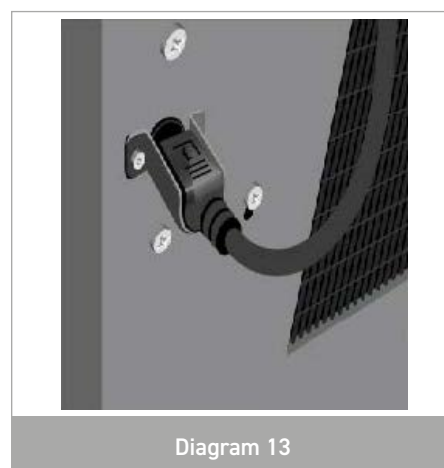
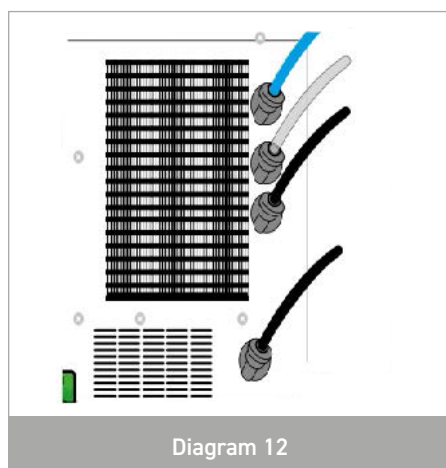

Diagram 10



Commissioning the Eco Sparkling

1. Check Filter Cartridge

Open front filter door by pulling in the indicated area and remove foam packing from under pre-installed filter cartridge. Ensure filter cartridge is fully pushed in and securely locked in place. Close front filter door.

2. Turn on Water Supply

Remove boiling module front panel. Remove foam packing piece from under filter canister. Ensure filter is securely locked back into place. Turn on water supply tap and ensure that there are no leaks.

Plug both boiling module power lead and chiller module power lead into power points.

Switch boiling module only on. Do not switch chiller on at this stage.

If plugged into an XL Tap, commissioning will begin automatically (Skip to initial fill section).

If plugged into an XT Motion Dispenser, skip to Step 2 below.

When plugged into an MMT Tap, following additional steps need to be taken:

1. Temporarily swap the red and black tap tubes so that the red boiling tube is connected to the vent outlet of the unit and the black vent tube is connected to the boiling outlet of the unit. This allows for increased venting during calibration.
2. Switch power point on and wait for at least 3 seconds.
3. Press and hold the PRESSURE RELIEF SWITCH for 10 seconds (the FILTER CHANGE LED will be illuminated).
4. Release the PRESSURE RELIEF SWITCH, the FILTER CHANGE LED will flash in a sequence indicating current tap setting:
 - i. 1 flash = QL Tap
 - ii. 2 flashes = XL Tap
 - iii. 3 flashes = XT/XR Tap
 - iv. 4 flashes = AL (Multifunction Mixer Tap and XT Motion)
5. To change the tap type to MMT or XT Motion, press the PRESSURE RELIEF SWITCH once and it will cycle to the next option.
6. When AL is selected (Four flashes), push and hold the PRESSURE RELIEF SWITCH until the POWER LED blinks.

Initial Fill:

During the initial boiling filling, red dispenser LED flashes rapidly. Water level in the hot tank rises until it reaches the lower-level sensor.

Boiling water temperature calibration

IMPORTANT: During hot water calibration mode, cold water delivery is disabled, and chiller module cannot be commissioned until calibration cycle is complete. Hot water calibration cycle can be aborted by turning the power off and back on again.

The hot tank will first fill to the height of the low level sensor. The water is then heated until it reaches boiling point. The unit will continue to boil for up to 30 seconds while the temperature sensor calibrates.

WARNING: Steam and small amounts of hot water may be discharged from the taps and vent during this period.

While calibration is underway the hot water indicator (red) will double blink rapidly. The hot water set point is calibrated 0.5°C below the boiling point. Once calibrated the unit will resume normal operations and the calibration data is saved. The unit will not re-calibrate under normal circumstances.

- 6a. For Multifunction Mixer Tap swap the red and grey silicon tap tubes back so that the red boiling tube is connected to the boiling outlet of the unit and the grey vent tube is connected to the vent outlet of the unit. This is a critical step.

If further boiling water calibration is required in the future, the following procedure should be followed:

- Turn the water supply off
- run the hot water until the hot tank is empty
- turn the power off for 5 seconds, then on again
- turn water supply on
- The unit will then re-calibrate its boiling point.

Fill Sparkling Chiller Module ice bank

- a. Fit black ice bank fill tube from chiller into 'AMBIENT OUTLET' fitting on Boiling Module. Refer to Diagram 10. NOTE: Do not turn on power to chiller at this stage.
- b. Lift cold water lever on dispenser tap. After about 15 seconds, water will show in the bottom of the sight glass tube. Watch this level rise as water is fed in.

IMPORTANT: If ambient water flow stops before ice bank is full, release cold lever and lift again.

- c. Release cold lever when water level reaches the minimum fill marker. Refer to Diagram 15. If tank is overfilled, disconnect sight glass elbow fitting from top bulkhead fitting and swing tube downwards and drain required amount of water. Water level in this tank will rise a little later as an ice bank forms.
- d. Disconnect $\varnothing 6$ mm black fill tube from boiling module ambient water outlet fitting. Fit cap supplied in installation kit onto end of tube. Coil and tuck black tube behind modules for later use.
- e. Connect clear $\varnothing 6$ mm tube from chiller module to the boiling module fitting labeled '**AMBIENT OUTLET**'.

Chiller set up

- a. Ensure Chiller power lead is plugged into power point. Switch power point on.
- b. Ensure chiller module power switch located at rear of module is turned on. (Diagram 14)
- c. Soda water pump starts to run.
- d. Lift chilled lever on dispenser and let the water run until it stops automatically. (60s)
- e. Return the chilled lever to the center position.
- f. Soda water pump continues to run until soda tank is full.

Set up CO₂ system

- a. Screw CO₂ cylinder into CO₂ regulator and hand tighten. Some gas may escape during this process. Refer to instruction on pg 5.
- b. Open the CO₂ regulator by turning the black knob clockwise (Diagram 13)
- c. Set the pressure between 3 and 4 bar for the right level of carbonation.
- d. Press both tap levers and dispense water and ensure the gas pressure stabilizes.

IMPORTANT: Water carbonation levels will continue to increase until water in the soda canister has become chilled and air has been dispelled.

Purging air from the CO₂ system

Air trapped in the soda tank is detrimental to the production of sparkling water and full carbonation may not be reached until 2-3 days of use. To speed this process, it is beneficial to purge the tank with CO₂ using the following procedure:

- a. Lift both tap levers and allow soda water to flow.
- b. Continue to run the tap until the tank is empty and gas flows from the outlet. Soda water feed pump will continue to run.
- c. Release tap levers. Wait until soda water pump stops. Press both tap levers together and check that water flows.
- d. Press cold lever only and check that water flows.

Set Chilled Water Temperature

If temperature adjustment is desired, ensure dial is set no higher than 5. **Warning: Setting the thermostat higher than 5 can risk unit freezing up and being damaged.** Refer to Billi User Guide for more information. Chiller refrigeration system will run continuously for approximately 2 – 3 hours as ice is formed in the ice bank. As a significant amount of heat is dispelled during this time, it is advisable to leave a cupboard door ajar during the initial cool down. As ice expands, the water level in the ice bank tank will rise slightly. Check water level is within operating range on sight glass level markings. Water level can be reduced if necessary. See Diagram 15. Press both tap levers and dispense water and ensure the gas pressure stabilizes.

INSTALLER TIP: To drain water from ice tank, disconnect upper sight-glass fitting, swing tube downwards and drain water into a cup or container.

Adjusting carbonation level

It is advisable to wait for cold water temperature to stabilize and air to be purged from the sparkling water unit before adjusting the carbonation level. Initial set point may vary once the unit is running. You may need to adjust the pressure once the system has stabilized. A pressure between 3 and 4 Bar will typically provide the right level of carbonization.

IMPORTANT: CO₂ pressure must not exceed 5 bar Re-check connections for leaks. Explain operation to user.

Adjusting Sparkling Flow Rate via Flow Adjuster:

- Insert 6 mm Allen key into flow adjuster and turn anti clockwise until stop is reached as per diagram 16.
- Dispense sparkling water and allow water to flow. Note the flow rate of sparkling water.
- Gradually turn adjuster clockwise until desired sparkling water flow rate is achieved

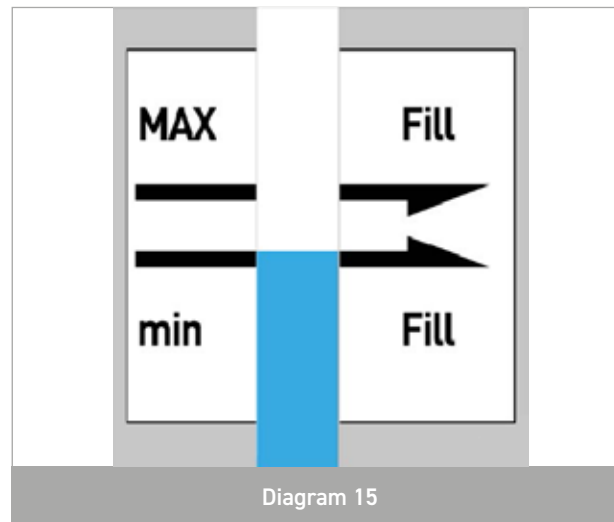
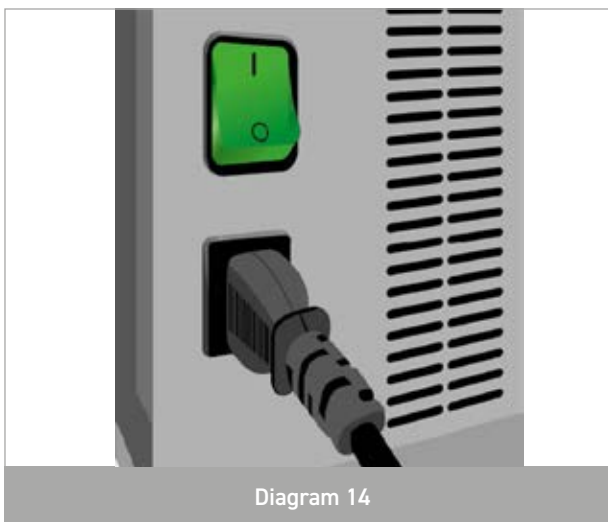

Basic unit operation for XL Tap

- Left hand lever dispenses boiling water. Right hand lever dispenses chilled water. Pressing or lifting both dispenser levers together dispenses sparkling chilled water.
- Dispenser levers can be pressed for single cup delivery or lifted for continuous flow. Levers will latch when lifted and can be released with a slight touch.
- Red and blue dispenser lights flash when water is initially heating and cooling and remain steady when set temperatures are reached. Refer to Eco Sparkling User Guide for further operational instructions.

Basic Unit Operation for MMT

- Use corresponding lock and dispense buttons.
- Press and hold for single cup delivery.
- Double Tap for a continuous flow. Please refer to Eco Sparkling User Guide for more instructions.
- Icon lights flash when water is initially heating and cooling and remain steady when set temperatures are reached.

Basic Unit Operation for XT Motion

- Use corresponding lock and dispense buttons.
- Position your hand at the rear of the tap body to unlock boiling water via touchless operation.
- Now hold your hand over the top of the boiling icon on the UI panel to begin dispensing.
- Place your hand on the left side of the tap body for sparkling water and on the right side for dispensing the cold water via touchless operation.
- Icon lights flash when water is initially heating and cooling and remain steady when set temperatures are reached.

Installation and Commission Checklist

- Filter packing foam removed from under filter cartridge.
- All other packaging films and labels removed.
- Dispenser mounted securely. Retaining screw on rear back of dispenser re-fitted for XL/ XT Motion Dispensers.
- Dispenser swivels 45° in each direction if activated (locking piece removed). (XL Tap Only)
- Tubing is cut to correct lengths and not kinked, twisted, or sagging. Red and grey silicone tubes have continuous fall.
- Tubing secured correctly. Silicone tubes secured with spring clamps, PE tubes fully inserted, and nuts correctly tightened.
- Water main flushed before connection to appliance.
- Appliance connected to COLD mains water supply.
- Sufficient clearance around unit and dispenser as recommended.
- Power circuit fitted with an RCD (earth leakage protection device).
- Sawdust and any other debris cleaned out of cupboard area.
- Initial program settings correctly set for dispenser tube length.
- Time and date correctly set.
- Appliance heating and cooling correctly after automatic commissioning sequence. Red and blue dispenser icons flashing (or on continually when correct temperature reached).
- CO₂ pressure correctly set with no leaks.
- Sparkling water flow rate correctly set.
- Boiling and chilled water flow steady.



Please scan the QR code for all support information.

Billi Australia Pty Ltd

P 1800 812 321
W www.billi.com.au

Billi New Zealand Ltd

P 0800 636 0 636
W www.billi.co.nz

Billi®

Designed and manufactured in Australia.

Billi® is a registered trademark of Billi Australia Pty Ltd. © Copyright protected.

Billi Australia Pty Ltd has a policy of continual improvement, all details are subject to change without notice. All goods are sold subject to our published terms and conditions.

Billi[®]